

零件目录 PARTS CONTENTS

1. 机壳部件(1) FRAME COMPONENTS(1)	1
2. 机壳部件(2) FRAME COMPONENTS(2)	3
3. 机壳部件(3) FRAME COMPONENTS(3)	5
4. 下轴部件 LOWER SHAFT COMPONENTS	7
5. 上轴部件 UPPER SHAFT COMPONENTS	9
6. 针杆部件 NEEDLE BAR COMPONENTS	11
7. 护针部件 NEEDLE GUARD COMPONENTS	13
8. 弯针部件 LOOPER COMPONENTS	15
9. 送布部件 MAIN FEED MECHANISM COMPONENTS	17
10. 差动部件 DIFFERENTIAL FEED MECHANISM COMPONENTS	21
11. 抬压脚部件 PREESSER FOOT LIFTER COMPONENTS	23
12. 绷针部件 STRETCH NEEDLE COMPONENTS	24
13. 过线器部件 THREAD GUIDE MECHANISM COMPONENTS	27
14. 过线部件 THREAD GUIDE COMPONENTS	29
15. 下过线器部件 LOWER THREAD TENSION COMPONENTS	31
16. 供油部件 LUBRICATION MECHANISM COMPONENTS	33
17. 油泵部件 PUMP COMPONENTS	35
18. 机针冷却器部件 NEEDLE COOLING MECHANISM COMPONENTS	37
19. 线架部件 THREAD STAND COMPONENT	39
20. 附件 ACCESSORIES PARTS	41
21. 导布部件 FABRIC GUIDE COMPONENTS	43
22. (500B-02/02HY/02QG/02DN)专用部件 SPECIFIC PARTS (FOR 500B-02/02HY/02QG/02DN)	45
23. (500B-05)专用部件(1) SPECIFIC PARTS (1) (FOR 500B-05)	47
24. (500B-05)专用部件(2) SPECIFIC PARTS (2) (FOR 500B-05)	49
25. (500B-05)专用部件(3) SPECIFIC PARTS (3) (FOR 500B-05)	51
26. (500B-05)专用部件(4) SPECIFIC PARTS (4) (FOR 500B-05)	53
27. (500B-05)专用部件(5) SPECIFIC PARTS (5) (FOR 500B-05)	55
28. (500B-05)专用部件(6) SPECIFIC PARTS (6) (FOR 500B-05)	57
29. (500B-02HY)专用部件 SPECIFIC PARTS (FOR 500B-02HY)	59
30. (500B-04)专用部件 SPECIFIC PARTS (FOR 500B-04)	63
31. (500B-21)专用部件 SPECIFIC PARTS (FOR 500B-21)	65
32. (500A-01)专用部件 SPECIFIC PARTS (FOR 500A-01)	67

1. 机壳部件(1) FRAME COMPONENTS(1)

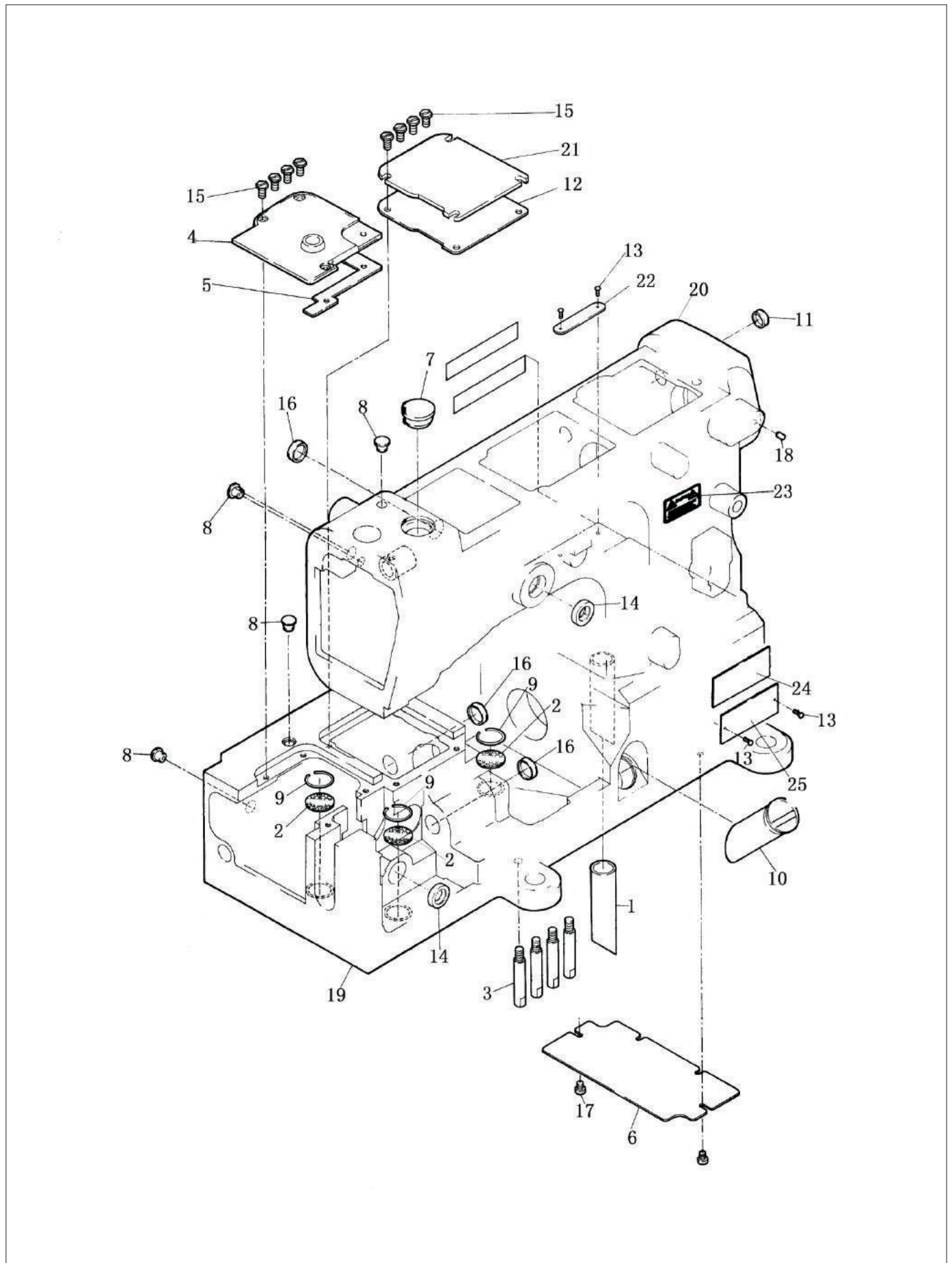

1. 机壳部件(1) FRAME COMPONENTS(1)

序号 NO.	注解 NOTE	图号 REF NO.	名称	DESCRIPTION	数量 AMT
1		301-01-01	机壳竖回油管	Machine Frame Oil Stand Pipe	1
2		301-01-02	过滤网20目	Filter Halfone	3
3		301-01-03	机座螺钉	Machine Mounting Screw	4
4		301-01-04	针距按钮盖	Push Button Cover (needle)	1
5		301-01-05	针距按钮盖防油垫	Oil Protecting Gasket	1
6		301-01-06	底罩板	Bed Hood Plate	1
7		301-01-07	闷头	Plug Stud	1
8		301-01-08	闷头	Plug Stud	4
9		28-16816200-08	挡圈内孔	Thread Take-up Lever Guard	3
10		301-01-10	油量指示窗	Oil Indication Window	1
11		301-01-11	闷头	Plug Stud	1
12		301-01-12	弯针传动盖油垫	Oil Gasket	1
13		101-01-14	铆钉 $\Phi 2 \times 4$	Rivet $\Phi 2 \times 3$	6
14		32-09440190-09	挑线轴骨架密封圈	Framework Airproof Ring	2
15		12-90400820-01	针距按钮盖螺钉	Push Button Cap Screw	8
16		301-01-14-2	防油圈	Oil Shield Coil Protecting Ring	3
17		12-40400525-01	螺钉	Screw	2
18		301-01-23	指示销	Direction Of Pin	1
19		301-01-27	机座	Machine Seat	1
20		301-01-28	机壳	Arm	1
21	#01	301-01-29	弯针传动仓板	Looper Driver Plate	1
22		44-00000010-00	机身号码	Airframe Number	1
23		44-00000001-00	注意牌	Plate With Notice	1
24		301-01-32	商标牌	Plate With Trademark	1
25		301-01-33	型号牌	Plate With Model	1
26		41-20502500-00	拼装开口销 $\Phi 5 \times 25$	Pin $\Phi 5 \times 25$	2
27		12-61003022-01	拼装螺钉	Screw	4
28		44-00000003-41	机针标签(UYX128GAS 11#)		1
29		31-15026500-09	O型圈	O-ringn	1

Note:
#01...For -7不用

2. 机壳部件(2) FRAME COMPONENTS(2)

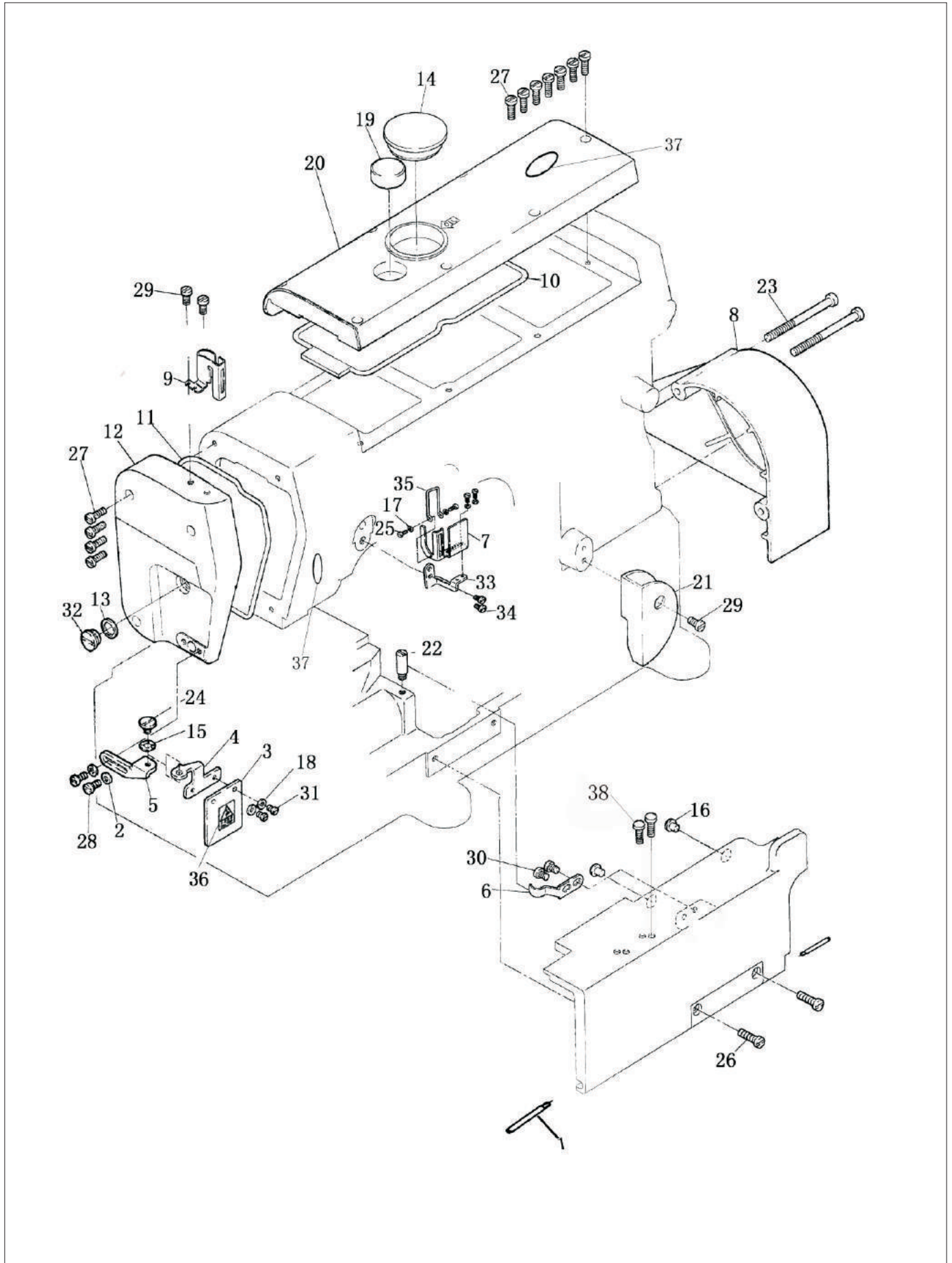

2. 机壳部件(2) FRAME COMPONENTS(2)

序号 NO.	注解 NOTE	图号 REF NO.	名称	DESCRIPTION	数量 AMT
1		301-02-01	穿线罩销轴	Threading Cover Pin	1
2	#02	21-04308090-02	垫圈	Washer	2
3	#02	301-02-03	防护罩	Shield	1
4	#02	301-02-04	防护罩支架	Shield Bracket	1
5	#02	301-02-05	防护罩座	Shield Seat	1
6		301-02-06	穿线罩弹簧	Threading Cover Spring	1
7	#03	340-02-07	挑线防护罩	Threading Cover Spring	1
8		301-02-08	皮带罩	Belt Guard	1
9	#04	340-02-09	上挑线座罩	Thread Take-up Lever Guard	1
10		301-02-10	上盖密封垫	Upper Cover Gasket	1
11		301-02-11	面板密封垫	Face Cover Gasket	1
12		301-02-12	面板	Face Cover	1
13		301-02-14	面板密封圈	Face Cover Seal Ring	1
14		301-02-15	上盖闷头	Upper Cover Plug	1
15	#02	23-06405110-09	鞍型垫圈	Wave Washer	1
16		301-02-17	防震塞	Shockproof Plug	2
17	#03	21-04308090-02	垫片	Washer	4
18	#05	21-03208070-02	防护罩垫圈	Shield Washer	2
19		301-02-20	喷油窗	Sight Window	1
20		301-02-21	上盖	Upper Cover	1
21		301-02-22	底线过线导板	Thread Eyelet Guide Plate	1
22		301-03-14	过线连接柱	Thread Handler Link	1
23		12-60506020-01	皮带罩螺钉一字槽	Belt Guard Screw	2
24	#02	301-02-25	防护罩铰链螺钉	Shield Hinge Screw	1
25	#03	12-40400625-01	螺钉	Screw	4
26		12-40401625-01	穿线罩铰链螺钉	Threading Cover Hinge Screw	2
27		12-40401225-01	上盖螺钉	Upper Cover Screw	11
28	#02	12-40400825-01	上挑线座罩螺钉	Silicone Oil Thread Stand Screw	2
29		12-40400825-01	上挑线罩螺钉	Screw	3
30		12-40400625-01	穿线罩弹簧螺钉	Threading Cover Spring Screw	2
31		12-40300625-01	防护罩螺钉	Shield Screw	2
32		301-02-33	面板螺钉	Face Cover Screw	1
33	#06	340-02-34	护板支架	Shield Bracket	1
34	#06	12-40601025-01	螺钉	Screw	2
35	#06	340-02-36	挑线防护罩钢丝	Steel Wire	1
36	#01	44-00000006-00	注意牌(安全)	Plate With Notice	1
37		44-00000004-00	注意牌	Plate With Notice	1
38	#07	12-40501125-01	螺钉	Screw	2

Note:

#01...For -7不用

#02...For -5、-4、-7不用

#03...For -5、-02HY不用

#04...For -02HY不用

#05...For -5、-4不用

#06...For -5、-02HY、-7不用

#07...For -1、500A-01专用

3. 机壳部件(3) FRAME COMPONENTS(3)

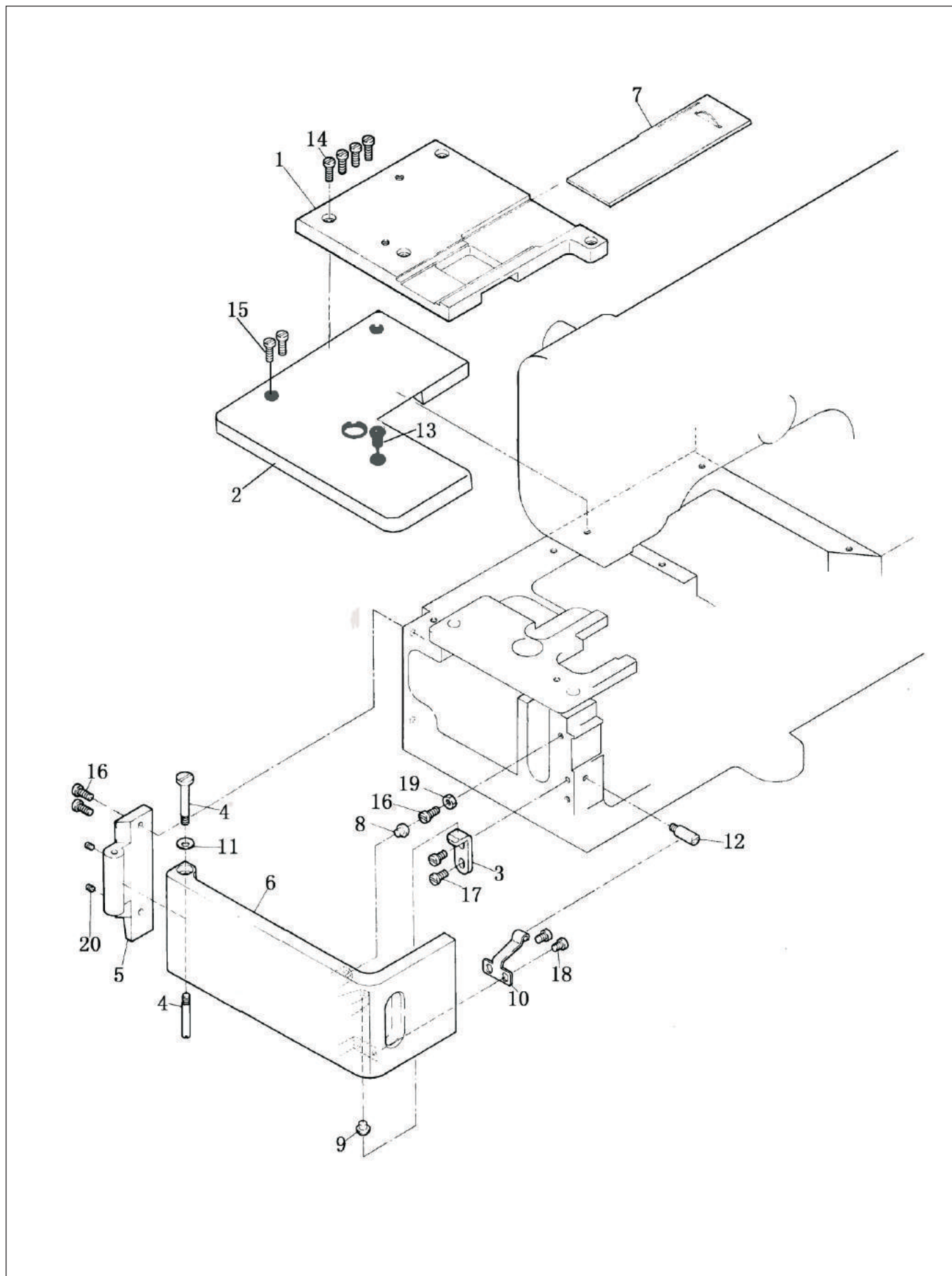

3. 机壳部件(3) FRAME COMPONENTS(3)

序号 NO.	注解 NOTE	图号 REF NO.	名称	DESCRIPTION	数量 AMT
1	#08	301-03-01	缝台上罩	Sewing Plate Uper Cover	1
2	#09	301-03-03	缝台前板	Sewing Plate Front Cover	1
3		301-03-04	防震板	Shockproof Board	1
4		301-03-06	铰链连接上螺钉	Hinge Link Screw	2
5		301-03-07	前罩铰链板	Hinge Board	1
6	#10	301-03-08	前罩	Frontal Mantle	1
7	#01、#04	301-03-09	推板	Slide Plate	1
	#30	338-03-09	推板	Slide Plate	1
8		301-02-17	防震塞	Shockproof Plug	1
9		301-02-17	防震塞	Shockproof Plug	1
10		301-03-12	前罩板弹簧	Frontal Mantle Spring	1
11		22-05000000-08	弹簧垫圈	Spring Washer	1
12		301-03-14	前罩板定位螺钉	Frontal Mantle Screw	1
13	#01	12-10400820-01	缝台前板沉头螺钉	Sewing Plate Front Cover Screw	1
14	#01	12-40401225-01	罩板螺钉	Mantle Plate Screw	4
15		12-40401225-01	缝台前板螺钉	Sewing Plate Front Cover Screw	2
16		12-40401025-01	铰链螺钉	Hinge Screw	3
17		12-40400825-01	防震板螺钉	Shockproof Board Screw	2
18		12-40400625-01	前罩螺钉	Frontal Mantle Screw	2
19		14-60403020-01	螺帽	Nut	1
20		12-80300412-01	铰链上头螺钉	Hinge Upper Screw	2

Note:
 #01...For -7不用
 #08...For 500A-01、-7不用
 #09...For -5、-7不用
 #10...For -5不用
 #30...For -02HY专用

4. 下轴部件 LOWER SHAFT COMPONENTS

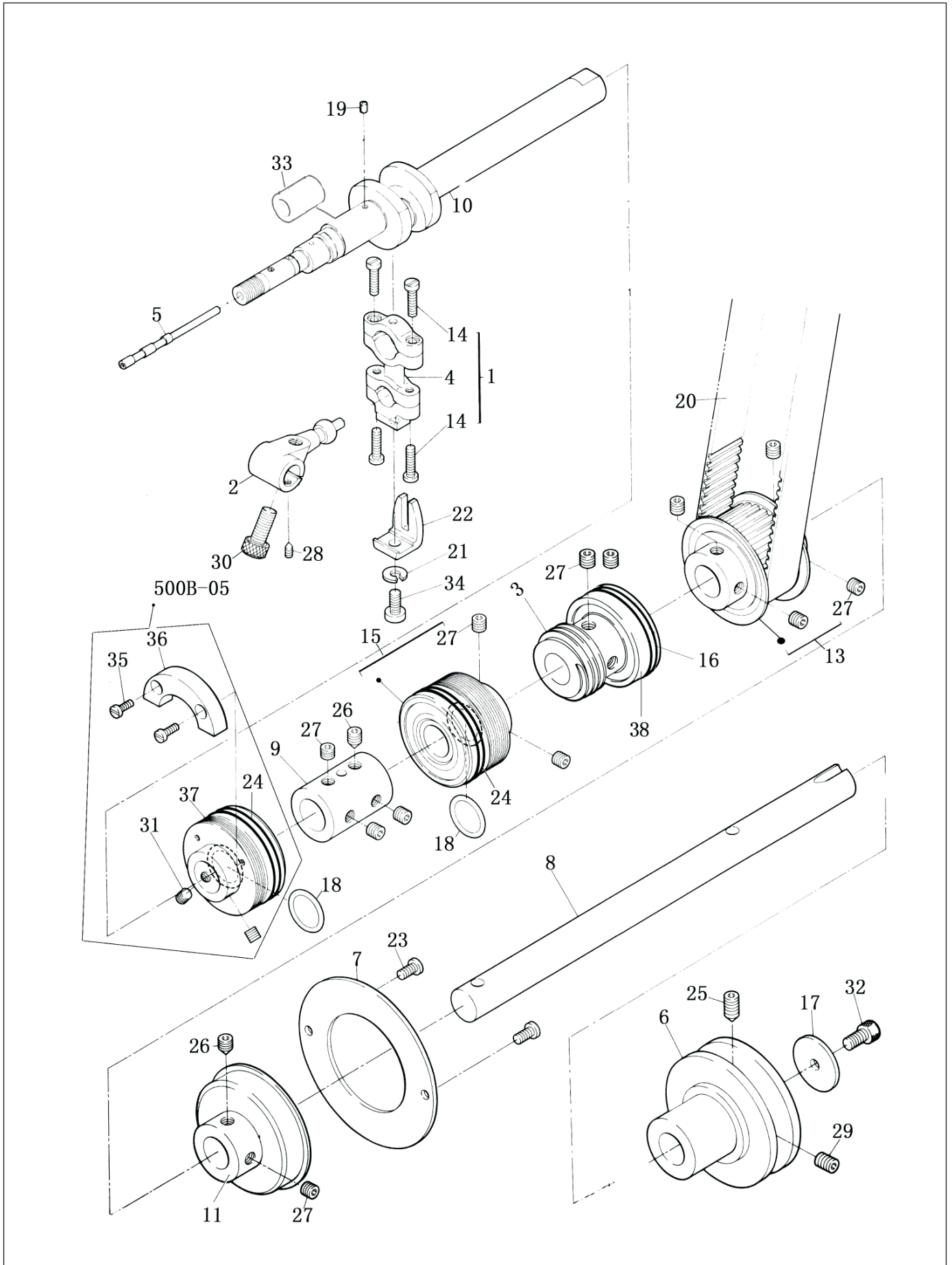

4. 下轴部件 LOWER SHAFT COMPONENTS

序号 NO.	注解 NOTE	图号 REF NO.	名称	DESCRIPTION	数量 AMT
1		301.04-01	弯针连杆组件(镀铜)	Looper Lever Complete	1
2		301.04-02	弯针球曲柄	Looper Ball Crank	1
3		301.04-03	油泵蜗杆	Oil Pump Worm	1
4		301.04-04	弯针连杆	Looper Lever Complete	-1
5		301.04-05	下轴油量调节芯针	Oil Flow Regulating Needle	1
6		301.04-06	从动轮	Traction Wheel	1
7	#11	301.04-07	压紧环	Impacted Loop	1
8		301.04-08	下轴后节轴	Lower Shaft Backside	1
9		301.04-09	联轴器	Link Bearing	1
10	#12	301.04-10	下轴前节	Lower Shaft Forepart	1
11	#12	301.04-11-00	下轴后衬套组件		1
		301.04-11	下轴后衬套	Lower Bearing Fittings Asm.	-1
		134.03-19	轴承 6304ZZNR	Lower Bearing Fittings Bearing	-1
		26-49010570-09	弹簧挡圈	Sprign Thrust Ring	-1
13		301.04-13	主动时规轮组件	Driving Wheel	1
14	#10	301.04-14	弯针连杆螺钉	Screw	-4
15		301.04-15	下轴中衬套组件	Lower Shaft Centre Bushing Asm.	1
		301.19-09	下轴中衬套轴承(6004)	Lower Shaft Centre Bushing Bearing	1
16		31-34518000-09	O型圈	O-ring	2
17		21-05220251-02	从动轮垫圈	Traction Wheel Washer	1
18		31-14818000-09	O型圈	O-ring	1
19		301.04-19	销子	Pin	-1
20		301.04-20	皮带 220×L075B	Belt 220×L075B	1
21	#10	22-05000000-08	开口垫圈	Snap Rign	1
22	#10	301.04-22	叉口	Fork	1
23	#13	12-40400625-01	压紧环螺钉	Impacted Loop Screw	2
24		31-32014000-09	O型圈	O-ring	2
25		12-80601042-01	从动轮定位螺钉	Traction Wheel Screw	1
26		12-85600842-01	联轴器定位螺钉锥端	Link Bearing Screw	2
27		12-85600512-01	螺钉	Screw	12
28	#10	12-80300442-01	球曲柄螺钉	Ball Crank Screw	1
29		12-80601012-01	从动轮定位螺钉	Traction Wheel Screw	1
30	#10	12-65601422-01	球曲柄螺钉	Ball Crank Screw	1
31	#13	12-80500512-01	前套螺钉	Front Bushing Screw	2
32		12-60501022-01	螺钉	Screw	1
33		301.04-35	下轴前套	Lower Shaft Front Bushing	1
34	#10	11-90110820-01	叉口螺钉	Fork Screw	1
35	#13	12-40300625-01	螺钉	Screw	2
36	#13	311.04-16-01	平衡块	Needle Driving Front Bearing	1
37	#13	311.04-16	下轴前衬套组件	Lower Shaft Front Bushing Asm.	1
	#13	301.19-09	下轴前衬套轴承	Lower Shaft Front Bushing Bearing	1
38		301.19-01-2	油泵蜗杆轴承(6204)	Oil Pump Worm Bearing	1

Note:
 #10...For -5不用
 #11...For 500A-01不用
 #12...For -21不用
 #13...For -5专用

5. 上轴部件 UPPER SHAFT COMPONENTS

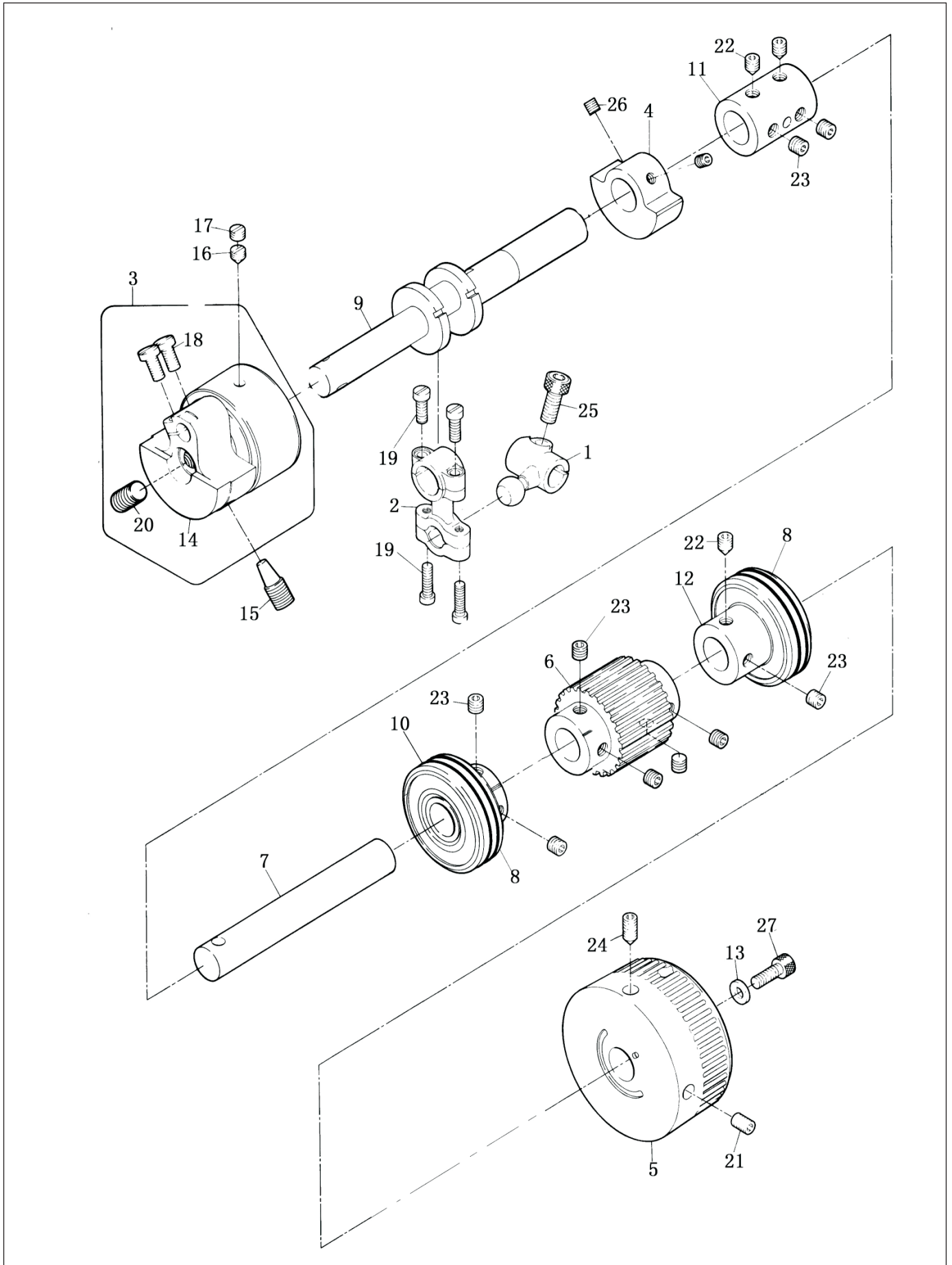

5. 上轴部件 UPPER SHAFT COMPONENTS

序号 NO.	注解 NOTE	图号 REF NO.	名称	DESCRIPTION	数量 AMT
1		301-05-01	上挑线球曲柄	Upper Tace-up Thread Ball Crank	1
2		301-05-02	上挑线连杆	Upper Tace-up Thread Link Lever	1
3		301-05-03	针杆曲柄组件	Needle Bar Crank Asm.	1
		301-19-02	6203ZZ轴承	Bearing	2
4		301-05-04	平衡块(上)	Upper Balance Block	1
5	#10	301-05-05	上轮	Belt Wheel	1
6		301-05-06	从动时轮规	Follower Wheel	1
7	#10	301-05-07	上轴后节	Main Shaft Backside	1
8		31-34518000-09	O型圈	O-ring	4
9		301-05-09	上轴前节	Main Shaft Forepart	1
10	#10	301-05-10	上轴前衬套	Main Shaft Front Bushing	1
		301-19-01-2	上轴前衬套轴承(6204)	Bearing	1
11		301-04-09	联轴器	Link Bearing	1
12		301-05-12	后衬套组件	Main Shaft Back Bushing Asm.	1
		301-19-01-2	后衬套轴承(6204)	Bearing	1
13		21-05310100-02	上轮垫圈	Belt Wheel Washer	1
14	#12	301-05-14	针杆曲柄	Needle Bar Crank	1
15		12-85802032-01	定位螺钉长锥端紧定螺钉	Position Screw	1
16		12-85600630-01	定位螺钉	Screw	1
17		12-85600410-01	止夹螺钉	Screw	1
18		12-40501025-01	螺钉	Screw	2
19		12-40401225-01	连杆螺钉	Link Lever Screw	(4)
20		12-85801512-01	螺钉	Screw	1
21		12-80601042-01	上轮止夹螺钉	Belt Wheel Screw	1
22		12-85600842-01	后套定位螺钉尖端	Back Bushing Position Screw	3
23		12-85600512-01	螺钉	Screw	9
24		12-80601012-01	定位螺钉	Position Screw	1
25		12-65601422-01	球曲柄螺钉	Ball Crank Screw	1
26		12-80500512-01	平衡块螺钉	Balance Block Screw	2
27		12-60501622-01	上轮螺钉	Belt Wheel Screw	1

Note:
#10...For -5不用
#12...For -21不用

6. 针杆部件 NEEDLE BAR COMPONENTS

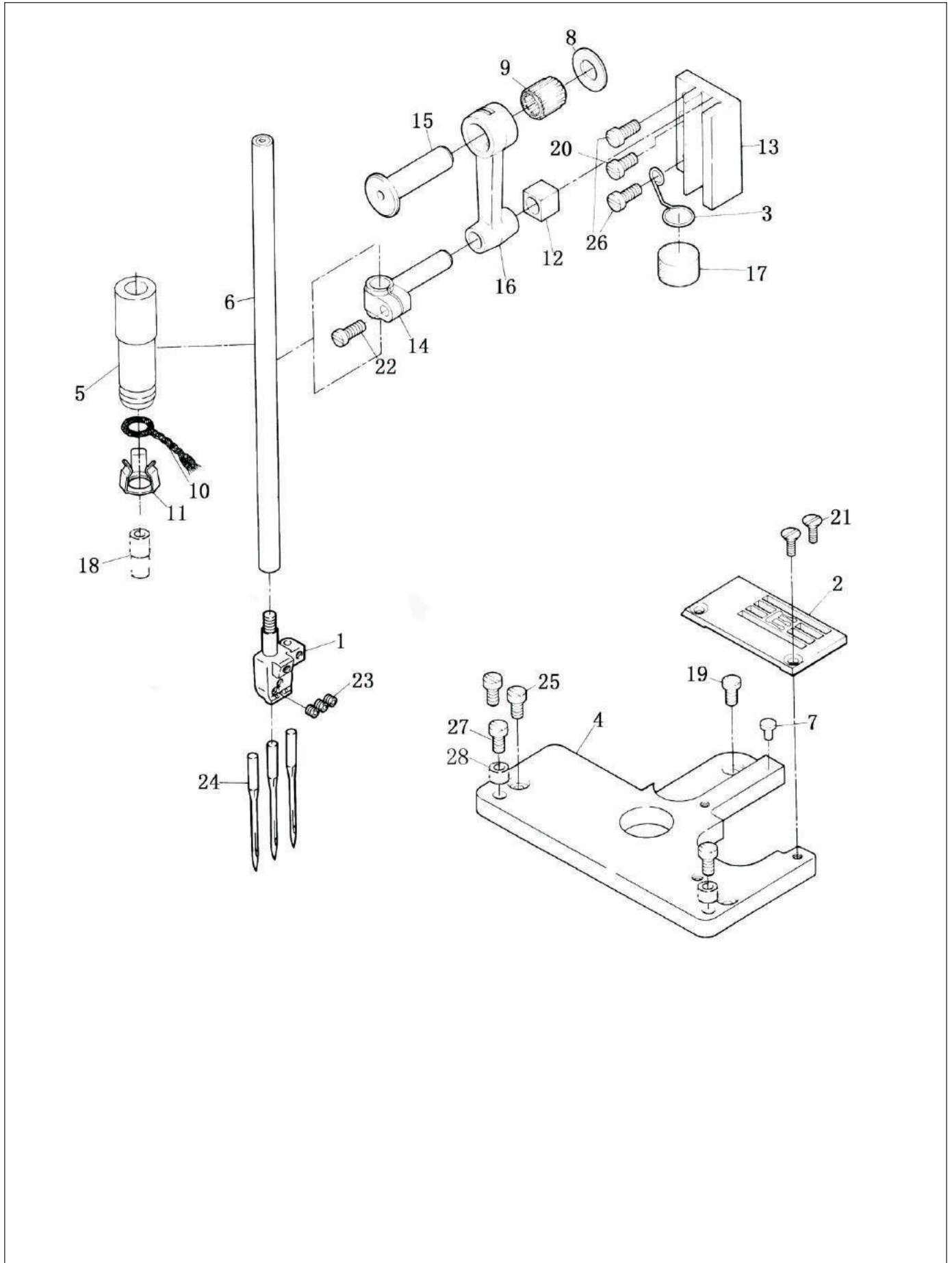

6. 针杆部件 NEEDLE BAR COMPONENTS

序号 NO.	注解 NOTE	图号 REF NO.	名称	DESCRIPTION	数量 AMT
1	#14	301-06-01	针夹	Needle Holder	1
	#16	312-06-01	针夹	Needle Holder	1
2	#15	301-06-02	针板	Needle Plate	1
	#16	312-06-02	针板	Needle Plate	1
3		301-06-03	油毡定位圈	Oil Felt Position Loop	1
4		301-06-04	针板接板	Needle Plate Link Plate	1
5		301-06-05	针杆上套	Needle Bar Upper Bushing	1
6		301-06-06	针杆	Needle Bar	1
7		301-06-07	防震塞	Shockproof Plug	1
8	#12	21-08210162-03	针杆连杆垫圈	Needl Bar Link Lever Washer	1
9		301-06-09	滚针轴承 $\phi 8 \times \phi 12 \times 12$	Needle Bearing $\phi 8 \times \phi 12 \times 12$	1
10		43-10250000-00	油线	Oil Wick	0.08
11		301-06-11	油线夹	Oil Wick Holder	1
12		301-06-12	针杆滑块	Needl Bar Slide Block	1
13		301-06-13	针杆滑块座	Needle Bar Slide Block Seating	1
14		301-06-14	针杆接头	Needle Bar Connecting Pole	1
15	#12	301-06-15	针杆连接销	Needle Bar Connecting Pin	1
16		301-06-16	针杆连杆	Needle Bar Link Lever	1
17		301-06-17	油毡	Oil Felt	1
18	#12	301-06-18	针杆下套	Needle Bar Lower Bushing	1
19		12-70400820-01	针板螺钉	Needle Plate Screw	1
20		12-40401025-01	螺钉	Screw	1
21		11-20090720-02	针板螺钉开槽半沉头	Needle Plate Screw	2
22		11-60111020-01	针杆接头螺钉	Needle Bar Connecting Screw	1
23		12-80300312-01	针夹螺钉	Needle Holder Screw	3
24	#12	301-06-24	机针	Needl	3
25		12-40400825-01	螺钉	Screw	2
26		12-40401225-01	螺钉	Screw	2
27		12-40400825-01	针板接板定位螺钉	Needle Plate Link Plate Pin	2
28		301-06-04-01	垫片	Washer	2

Note:
 #12...For -21不用
 #14...For -4、-6专用
 #15...For -02HY、-2、-5、-4、-3不用
 #16...For -6专用

7. 护针部件 NEEDLE GUARD COMPONENTS

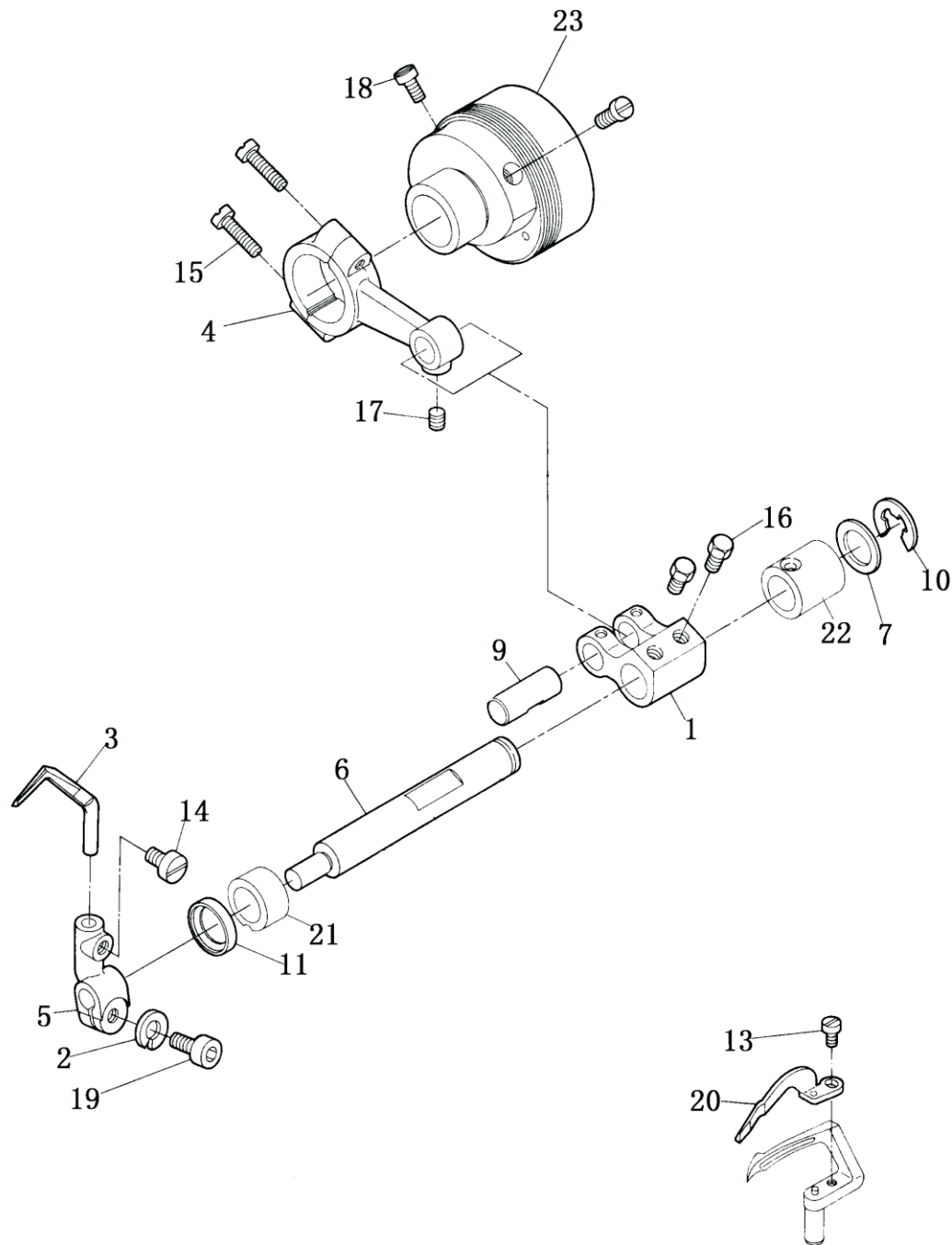

7. 护针部件 NEEDLE GUARD COMPONENTS

序号 NO.	注解 NOTE	图号 REF NO.	名称	DESCRIPTION	数量 AMT
1	#12	301-07-01	保针曲柄	Needle Guard Crank	1
2	#12	22-05000000-08	垫圈	Washer	1
3	#05	301-07-03	后保针	Rear Needle Guard	1
4	#12	301-07-04	保针连杆	Needle Guard Connecting Rod	1
5	#17	301-07-05	保针座	Needle Guard Base	1
6	#18	301-07-07	保针轴	Needle Guard Shaft	1
7	#12	21-10212142-01	垫圈	Washer	1
9	#12	301-07-10	保针曲柄销	Needle Guard Crank Pin	1
10	#12	24-07000000-09	开口挡圈	Snap Thrust Ring	1
11	#12	32-09430150-09	骨架防油圈	Framework Oil Shield	1
13	#19	12-40250425-01	保针螺钉	Needl Guard Screw	1
14	#19	12-40400625-01	螺钉	Screw	1
15	#12	11-40111425-01	保针曲柄螺钉	Needle Guard Connecting Rod Screw	(2)
16	#12	11-00110620-01	保针曲柄螺钉	Needle Guard Crank Screw	2
17	#12	12-80400412-01	螺钉	Screw	1
18	#12	12-80500612-01	螺钉	Screw	2
19		12-60501022-01	保针座螺钉	Needle Guard Base Screw	1
20	#05	301-07-21	前保针	Front Needle Guard	1
21	#12	301-07-23	保针轴左套	Needle Guard Shaft Left Bushing	1
22	#12	301-07-24	保针轴右套	Needle Guard Shaft Right Bushing	1
23	#10	301-04-16	下轴前衬套	Lower Shaft Front Bushing Asm.	1
24	#10	301-19-04	下轴前衬套轴承(6004)	Bearing(6004)	(1)
25	#10	31-14818000-09	O形圈	O-ring	(1)
26	#10	31-32014000-09	O形圈	O-ring	2

Note:
 #05...For -5、-4不用
 #10...For -5不用
 #12...For -21不用
 #17...For -5、-4、-21不用
 #18...For -5、-21不用

8. 弯针部件 LOOPER COMPONENTS

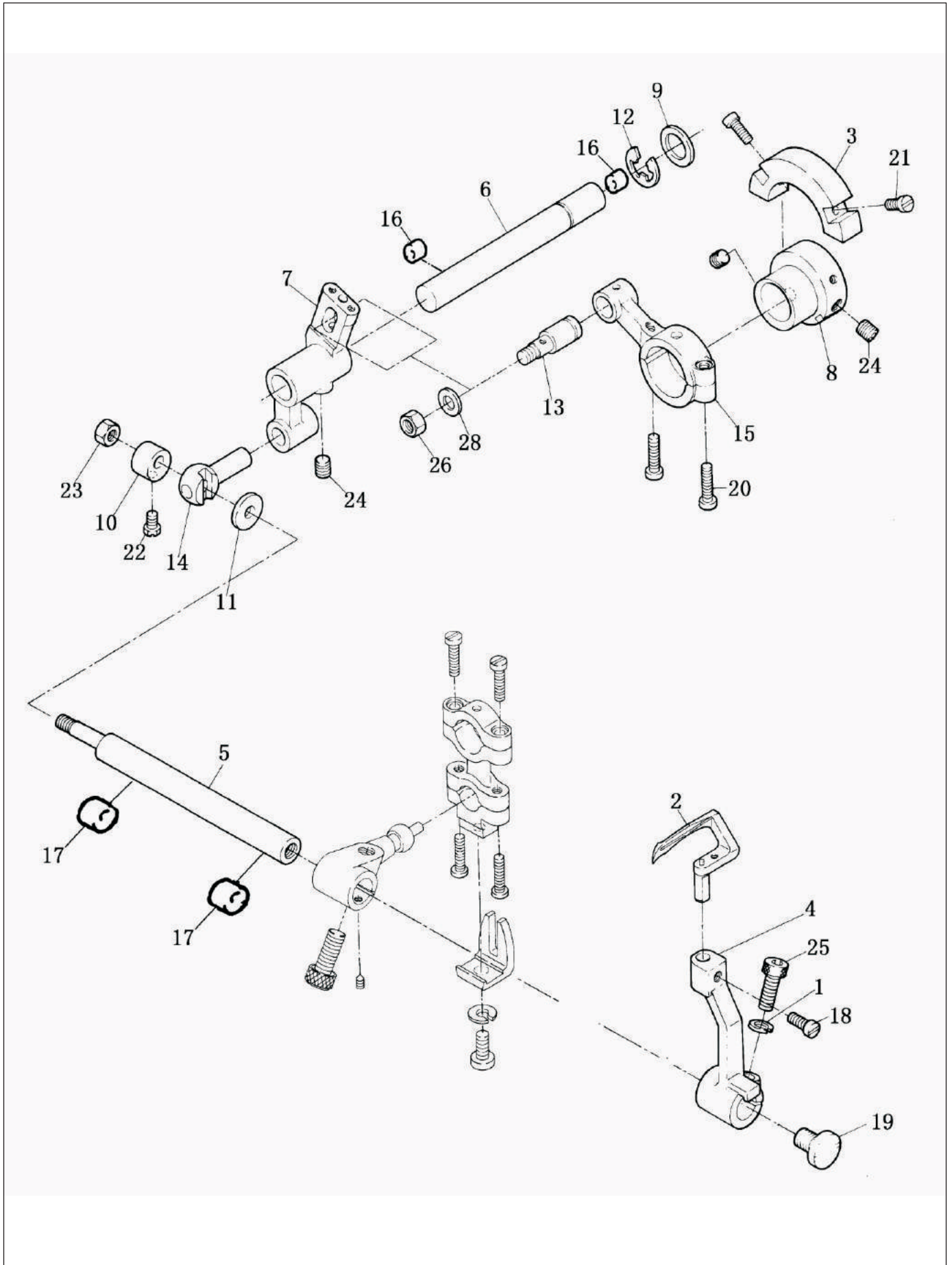

8. 弯针部件 LOOPER COMPONENTS

序号 NO.	注解 NOTE	图号 REF NO.	名称	DESCRIPTION	数量 AMT
1		22-05000000-08	垫片	Washer	1
2	#12	301.08-02	弯针	Looper	1
3	#10	301.08-03	平衡块(下)	Lower Balance Block	1
4	#20	301.08-04	弯针曲柄	Looper Crank	1
5	#19	301.08-05	弯针轴	Looper Shaft	1
6		301.08-06	弯针调节摆轴	Looper Regulate Driving Shaft	1
7		301.08-07	调节摆杆	Regulator Driving Bar	1
8	#18	301.08-08	偏心凸轮	Eccentricity Cam	1
9		21-10212142-01	垫圈	Washer	1
10		301.08-12	偏心紧圈	Eccentricity Thrust Ring	1
11		21-04615122-02	平垫圈	Washer	1
12		24-07000000-09	开口挡圈	Snap Thrust Ring	1
13		301.08-15	弯针调节柱	Looper Regulator Pole	1
14		301.08-16	接头	Connecting Pole	1
15	#18	301.08-17	弯针连杆组件	Looper Link Lever Asm.	1
16		301.07-24	弯针调节摆轴左/右套	Regulator Driving Shaft Bushing(left,right)	3
17		301.08-20	弯针轴前/后套	Looper Shaft Bushing (frong ,back)	1
18	#19	12-40400825-01	弯针刀槽螺钉	Looper Groove Screw	1
19	#19	12-75601020-01	弯针螺钉	Looper Screw	1
20	#18	11-40091425-01	连杆螺钉	Link Lever Screw	(2)
21	#10	12-40300625-01	平衡块螺钉	Balance Block Screw	2
22		11-90110820-01	紧圈螺钉	Thrust Ring Screw	1
23		14-60403020-01	螺帽	Nut	1
24		12-80500612-01	凸轮螺钉	Cam Screw	3
25		12-60501622-01	弯针曲柄螺钉	Looper Crank Screw	1
26		14-60504020-01	螺帽	Nut	1
28		21-05212121-03	垫圈	Washer	1

Note:

#10...For -5不用

#18...For -5、-21不用

#19...For -4不用

#20...For -4、-21不用

9. 送布部件 MAIN FEED MECHANISM COMPONENTS

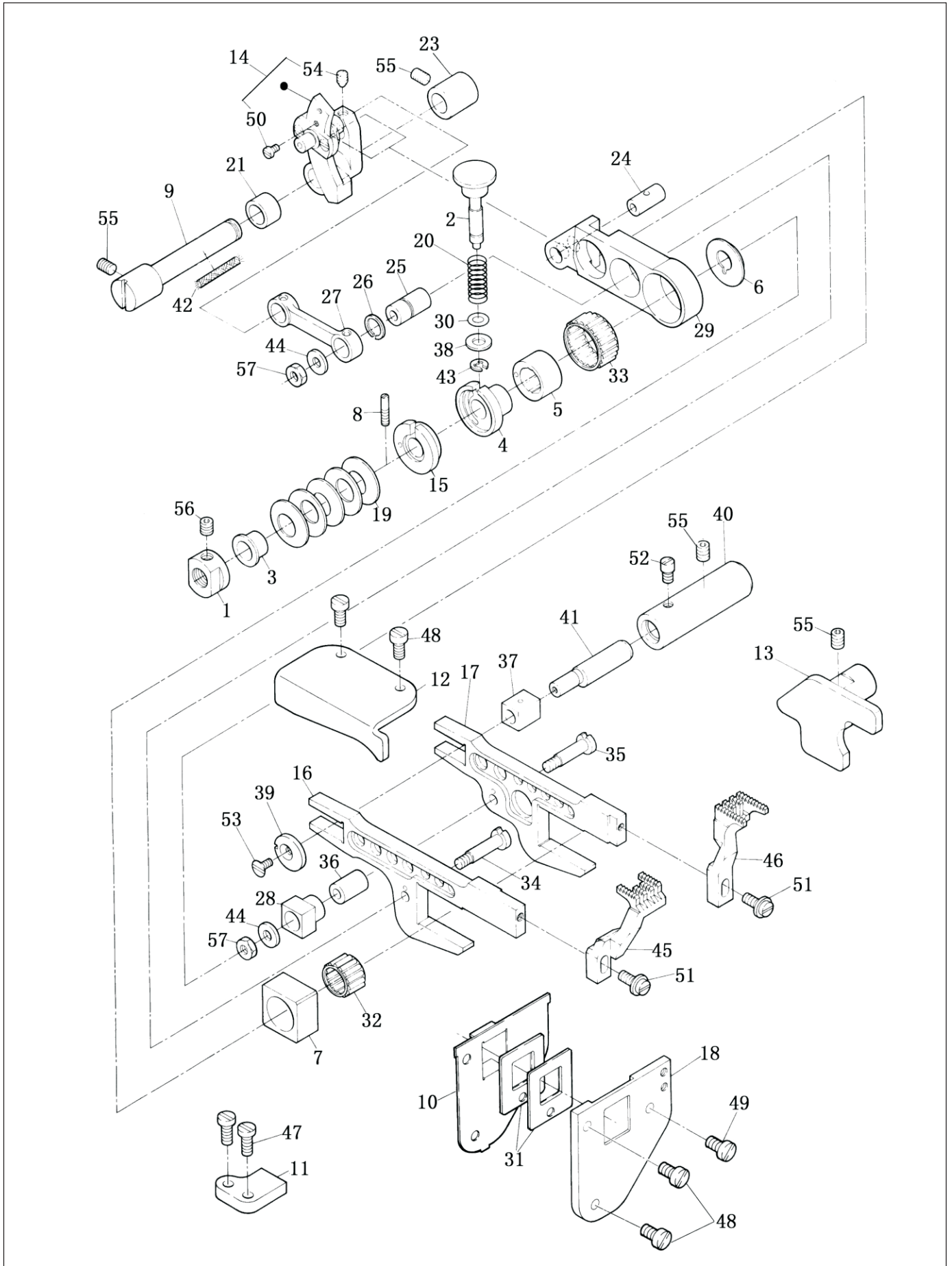

9. 送布部件 MAIN FEED MECHANISM COMPONENTS

序号 NO.	注解 NOTE	图号 REF NO.	名称	DESCRIPTION	数量 AMT
1		301.09-01	凸轮螺母	Cam Nut	1
2		301.09-02	针距按钮	Needle Distance Button	1
3		301.09-03	台阶套	Ladder Bushing	1
4		301.09-04	送布调节凸轮	Feed Dog Regulator Cam	1
5		301.09-05	凸轮	Cam	1
6		301.09-06	送布连杆垫圈	Feed Dog Link Lever Washer	1
7		301.09-07	牙架前滑块	Feed Rack Front Slide Block	1
8		301.09-08	销螺钉	Pin Screw	1
9		301.09-09	差动器轴	Differential Feed Shaft	1
10		301.09-10	垫板	Washer	1
11		301.09-11	左限位板	Left Stopper Plate	1
12		301.09-12	牙架上限位板	Feed Rack Upper Stopper Plate	1
13	#12	343.09-38	牙架右限位板	Feed Rack Right Stopper Plate	1
14		301.09-14	差动器组件	Differential Feed Assembly.	1
		301.09-14-01	差动器组件1	Differential Feed Assembly.	(1)
		301.09-14-02	差动器组件2	Differential Feed Assembly.	(1)
		301.09-14-03	差动器曲柄	Differential Feed Crank	(1)
		12-10300620-01	螺钉	Screw	(2)
15		301.09-15	针距调节套	Needle Distance Regulator Bushing	1
		301.09-16-00	牙架组件		1
16		301.09-16	差动牙架	Differentialfeed Rack	1
17		301.09-17	送布牙架	Feed Dog Rack	1
18	#10	301.09-18	弯针盖	Looper Cover	1
19		23-10310200-09	蝶形弹簧圈	Wave Washer	5
20		301.09-20	针距按钮簧	Needle Distance Button Spring	1
21		301.09-21	差动器隔套	Differential Feed Spacer	1
23		301.09-23	差动器轴套	Differential Feed Bushing	1
24		301.09-24	送布连杆销	Feed Dog Link Lever Pin	1
25		301.09-25	送布连杆销	Feed Dog Link Lever Pin	1
26		26-06810100-09	开口挡圈	Snap Ring	1
27		301.09-27	差动送布连杆	Differential Feed Link Lever	1
28		301.09-28	送布滑块	Feed Dog Slide Block	1
29		301.09-29	送布连杆	Feed Dog Link Lever	1
30		31-04020000-09	O型圈	O-ring	1
31		301.09-31	胶垫片	Rubber Washer	2
32		279.05-27	拾牙滑块轴承	Needle Bearing $\Phi 12 \times \Phi 15 \times 10$	1
33		301.09-33	滚针轴承 $\Phi 17 \times \Phi 21 \times 10$	Needle Bearing $\Phi 17 \times \Phi 21 \times 10$	1
34		301.09-34	连接螺钉	Connection Screw	1
35		301.09-35	送布滑块连接螺钉	Connection Screw	1
36		301.09-36	送布滑块套	Feed Dog Slide Block Bushing	1
37		301.09-37	牙架后滑块	Feed Dog Rack Back Slide Block	1
38		21-05310100-02	垫圈	Washer	1
39		301.09-39	垫圈	Washer	1
40		301.09-40	偏心轴套	Eccentric Bushing	1
41		301.09-41	牙架偏心轴	Eccentric Shaft	1
42		43-10250000-00	油线	Oil Wick	0.02
43		24-04000000-08	开口挡圈	Snap Ring	1
44		21-04615101-01	垫片	Washer	2
45	#21	301.09-45	差动送布牙	Differential Feed Dog	1
	#22	301.09-45(4.8)	差动送布牙(4.8)	Differential Feed Dog	1
		301.09-45(3.2)	差动送布牙	Differential Feed Dog	

9. 送布部件 MAIN FEED MECHANISM COMPONENTS

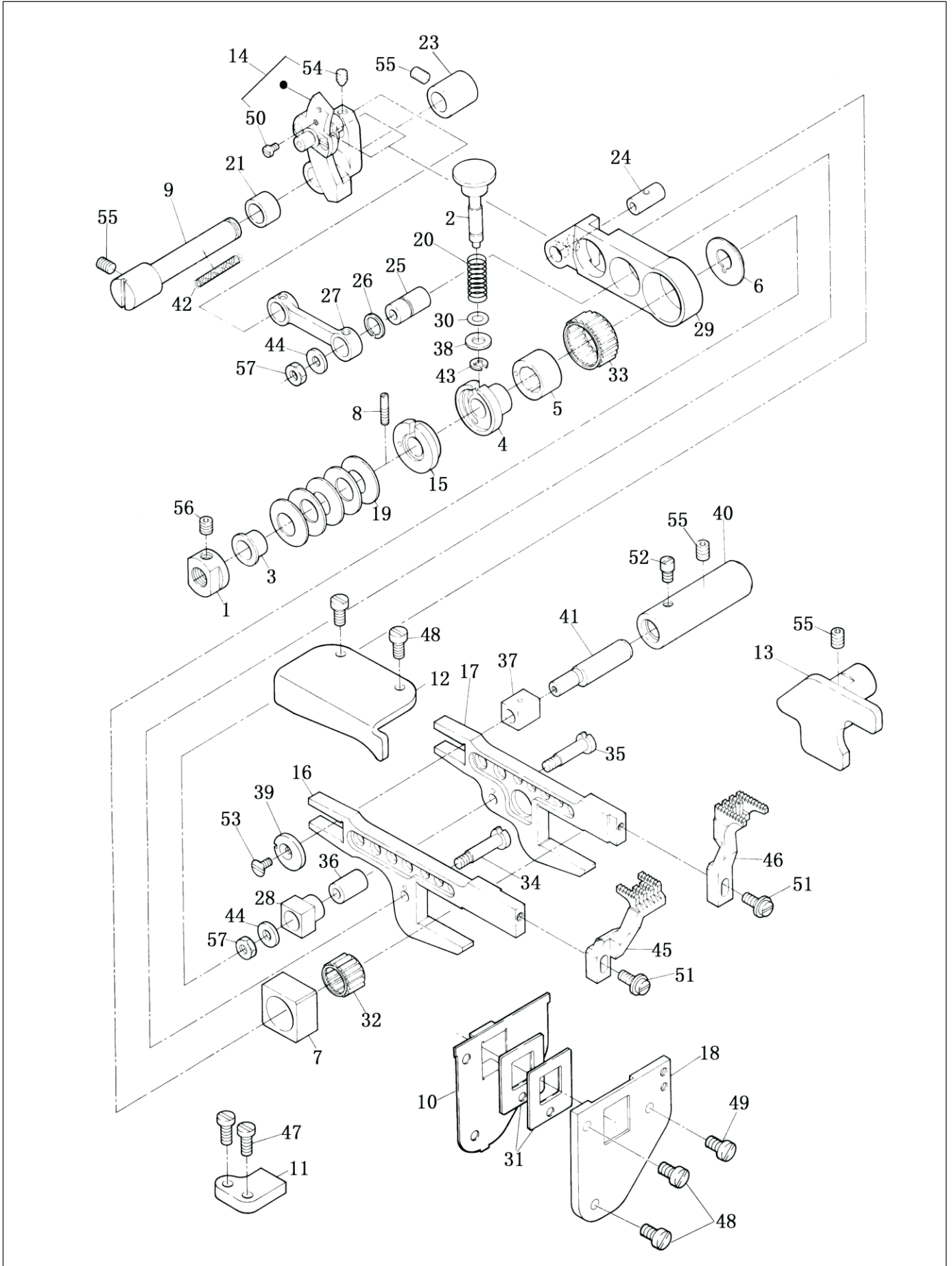

9. 送布部件 MAIN FEED MECHANISM COMPONENTS

序号 NO.	注解 NOTE	图号 REF NO.	名称	DESCRIPTION	数量 AMT
46	#16	312.09-45	差动送布牙	Differential Feed Dog	1
	#21	301.09-46	主动送布牙	Main Feed Dog	1
	#22	301.09-46(4.8)	主动送布牙(4.8)	Main Feed Dog	1
		301.09-46(3.2)	主动送布牙	Main Feed Dog	
47	#16	312.09-46	主动送布牙	Main Feed Dog	1
		12-40401025-01	螺钉	Screw	2
48		12-40400825-01	限位板螺钉	Stopper Plate Screw	4
49		12-70400820-01	螺钉	Screw	1
50		12-40250425-01	差动器螺钉	Differentialfeed Screw	2
51		301.09-51	牙架螺钉	Rack Screw	2
52		11-00110620-01	轴套螺钉	Bushing Screw	1
53		11-10080620-01	螺钉	Screw	1
54		12-80400542-01	螺钉	Screw	1
55		12-80500612-01	螺钉	Screw	4
56		12-80500512-01	螺钉	Screw	1
57		13-60114020-01	螺母	Nut	2

Note:
 #10...For -5不用
 #12...For -21不用
 #16...For -6专用
 #21...For -1、-21、500A-01、-02DN、-7专用
 #22...For -1、500A-01、-7专用

10. 差动部件 DIFFERENTIAL FEED MECHANISM COMPONENTS

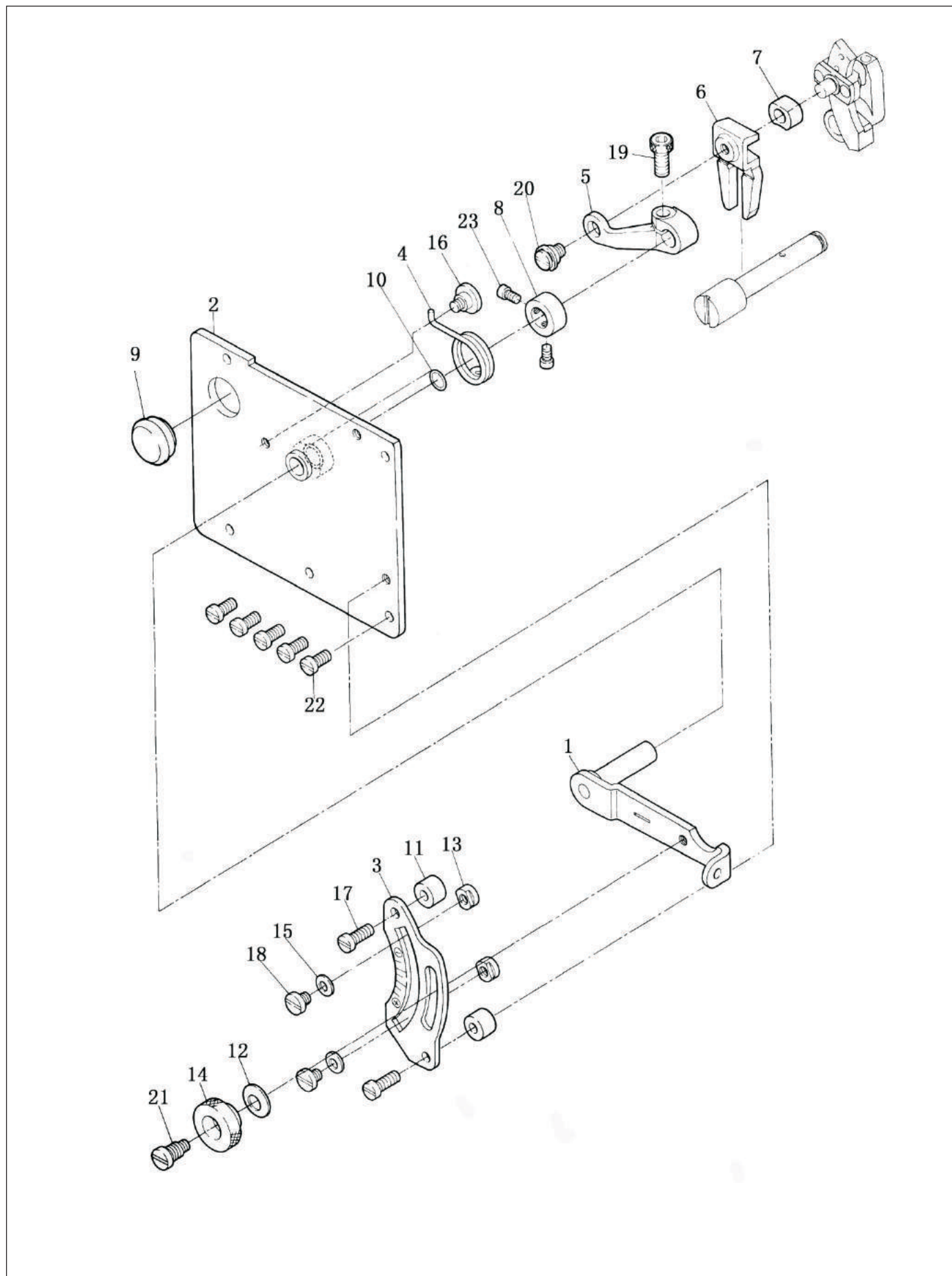

10. 差动部件 DIFFERENTIAL FEED MECHANISM COMPONENTS

序号 NO.	注解 NOTE	图号 REF NO.	名称	DESCRIPTION	数量 AMT
1		301.10-01	调节杆 (组件)	Adjusting Rod Asm.	1
		301.10-01-1	调节杆 (组件)	Adjusting Rod Asm.	(1)
		301.10-01-2	调节杆 (组件)	Adjusting Rod Asm.	(1)
2		301.10-02	差动调节板	Differential Feed Regulating Plate	1
		301.10-02-01	衬套	Bushing	(1)
3		301.10-03	差动调节刻度板	Differential Feed Regulating Graduation Plate	1
4		301.10-04	差动调节复位弹簧	Differential Feed Regulating Return Spring	1
5		301.10-05	差动调节曲柄	Differential Feed Regulating Crank	1
6		301.10-06	差动调节吊板	Differential Feed Regulating Fork Plate	1
7		301.10-07	滑块	Slide Block	1
8		301.10-08	差动板手紧圈	Thrust Ring	1
9		301.10-09	闷头	Plug	1
10		31-08018000-09	O型密封圈	Rubber Ring	1
11		301.10-11	刻度板隔套	Graduation Plate Spacer	2
12		23-06005120-09	蝶形垫圈	Wave Washer	1
13		301.10-13	螺母 (专用)	Nut	2
14		301.10-14	差动调节锁紧螺母	Locknut	1
15		21-04308090-02	平垫圈	Wave Washer	2
16		301.10-16	螺钉	Screw	1
17		11-40111225-01	螺钉	Screw	2
18		11-40110625-01	螺钉	Screw	2
19		12-60501222-01	螺钉	Screw	1
20		301.10-20	螺钉	Screw	1
21		301.10-21	锁紧螺钉	Screw	1
22		12-40400825-01	螺钉	Screw	5
23		11-00090620-01	螺钉	Screw	2

11. 抬压脚部件 PREESSER FOOT LIFTER COMPONENTS

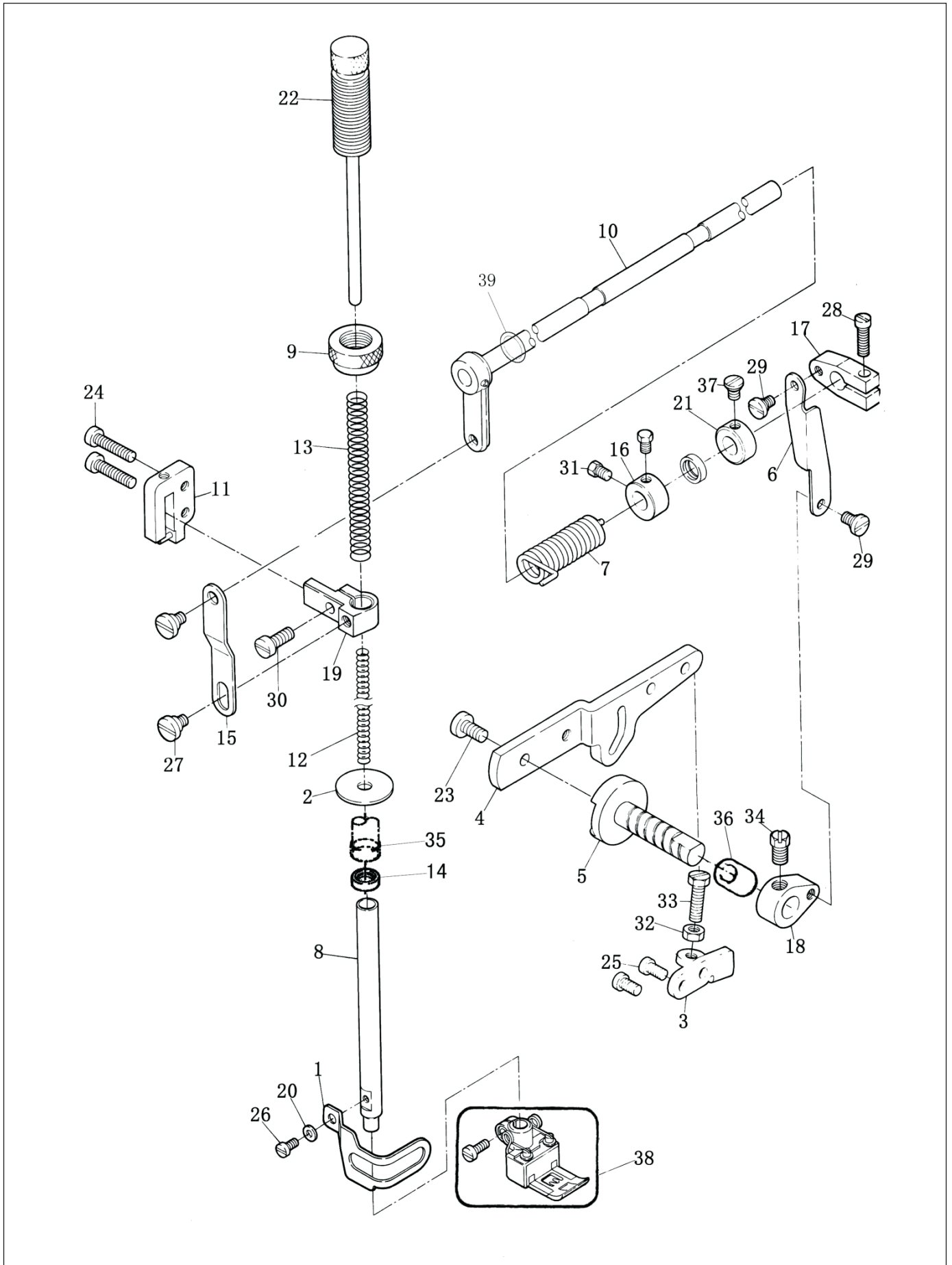

11. 抬压脚部件 PREESSER FOOT LIFTER COMPONENTS

序号 NO.	注解 NOTE	图号 REF NO.	名称	DESCRIPTION	数量 AMT
1	#18、#19	301.11-01	压紧防护罩	Presser Bar Shield	1
2		301.11-02	压紧杆防油罩	Rubber Washer	1
3	#01	301.11-03	限位板	Stopper Plate	1
4		301.11-04	抬压脚拉杆	Presser Foot Lifting Lever	1
5		301.11-05	拉杆座	Lever Base	1
6		301.11-06	抬压脚吊杆	Presser Foot Lifting Steeve	1
7		301.11-07	抬压脚弹簧	Presser Foot Lifting Spring	1
8		301.11-08	压紧杆	Presser Bar	1
9		301.11-09	调压螺母	Adjusting Nut	1
10		301.11-10	抬压脚轴组件	Presser Foot Lifting Shaft	1
		301.11-10-01	抬压脚轴	Presser Foot Lifting Shaft	(1)
		301.11-10-02	抬压脚轴曲柄	Presser Foot Lifting Shaft Crank	(1)
11		301.11-11	压杆导架座	Presser Bar Guide Bracket Base	1
12		301.11-12	调压内弹簧	Presser Regulating Inner Spring	1
13		301.11-13	调压弹簧	Presser Regulating Spring	1
14		32-08440150-09	骨架油封	O-ring	1
15		301.11-15	抬压脚吊板	Presser Foot Lifting Steeve	1
16		301.11-16	抬压脚轴紧圈	Thrust Ring	1
17		301.11-17	抬压脚曲柄	Presser Foot Lifting Crank	1
18		301.11-18	吊杆曲柄	Steeve Crank	1
19		301.11-19	压杆导架	Presser Bar Guide Bracket	1
20	#04	21-03208070-02	垫圈	Washer	1
21		301.11-21	限位紧圈	Thrust Ring	1
22		301.11-22	调压螺钉 (组件)	Adjusting Screw	1
		301.11-22-01	调压螺钉轴	Adjusting Screw Shaft	(1)
		301.11-22-02	调压螺钉	Adjusting Screw	(1)
23		12-60501022-01	螺钉	Screw	1
24		12-40402025-01	导架座螺钉	Bracket Base Screw	2
25	#01	12-40400825-01	螺钉	Screw	2
26	#04	12-40300625-01	螺钉	Screw	1
27		301.11-27	螺钉	Screw	2
28		11-70111420-01	螺钉	Screw	1
29		301.11-29	螺钉	Screw	2
30		11-40111225-01	螺钉	Screw	1
31		11-00110620-01	螺钉	Screw	2
32	#01	14-60504020-01	螺母	Nut	1
33	#01	12-90502520-01	螺钉	Screw	1
34		11-00160920-01	螺钉	Screw	1
35		343.11-12	压紧杆套	Presser Bar Bushing	1
36		301.11-36	拉杆座套	Lever Base Bushing	1
37		11-00110620-01	螺钉	Screw	1
38	#23	301.11-38	压脚 (组件)	Presser Foot	1
	#22	301.11-38(6.4)	压脚 (组件) (6.4)	Presser Foot	1
	#22	301.11-38(4.8)	压脚 (组件) (4.8)	Presser Foot	1
		301.11-38(3.2)	压脚	Presser Foot	1
	#16	312.11-38	压脚 (组件)	Presser Foot	1
39		31-07524000-09	O型圈	O-ring	1

Note:
 #01...For -7不用 #04...For -02HY不用
 #06...For -5、-02HY、-7不用
 #18...For -5、-21不用 #19...For -4不用
 #22...For -1、500A-01、-7专用
 #23...For -1、500A-01、-02DN、-7专用

12. 绷针部件 STRETCH NEEDLE COMPONENTS

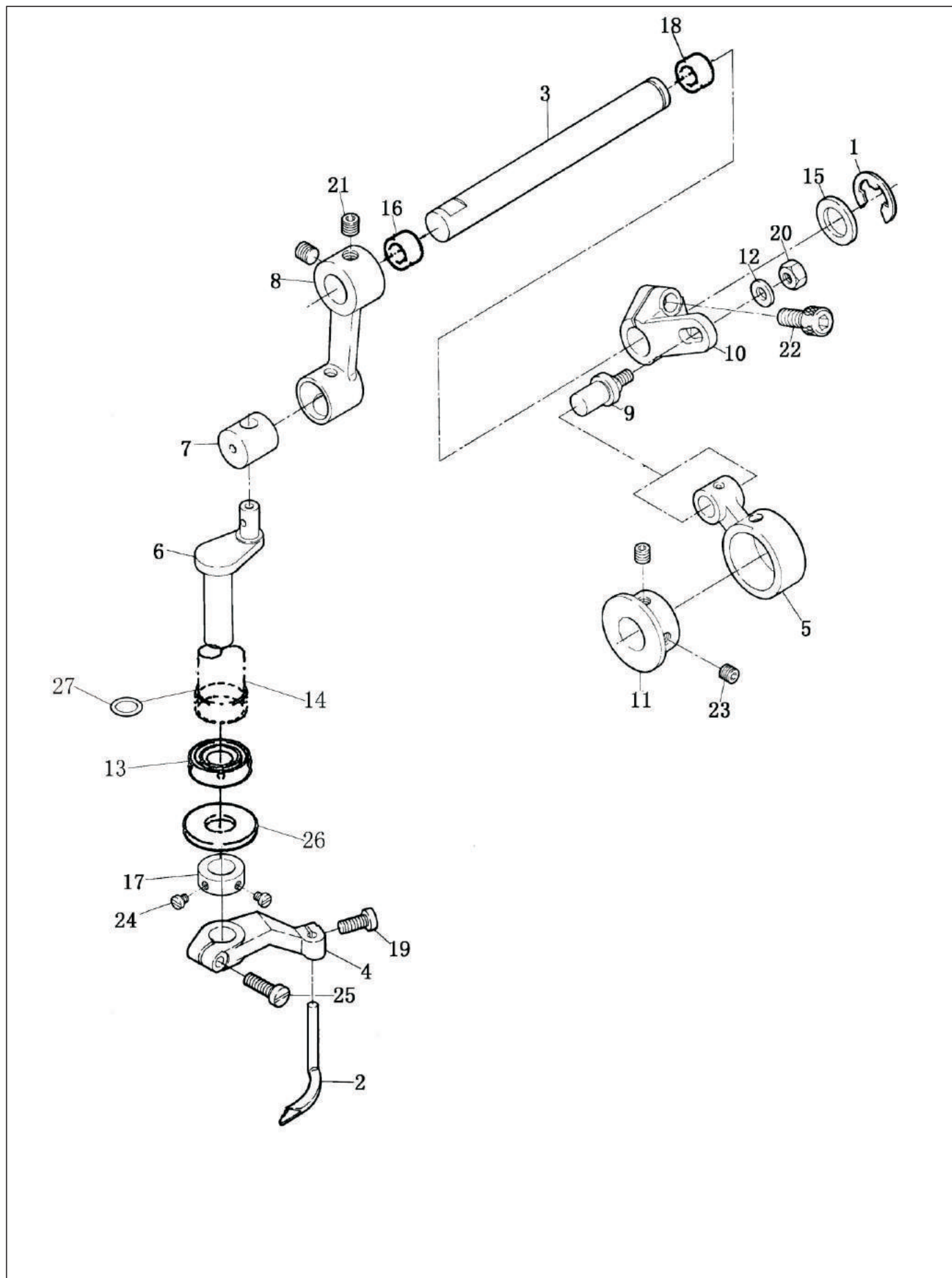

12. 绷针部件 STRETCH NEEDLE COMPONENTS

序号 NO.	注解 NOTE	图号 REF NO.	名称	DESCRIPTION	数量 AMT
1	#24	24-10000000-09	开口挡圈	Snap Ring	1
2	#24	301.12-02	绷针	Stretch Tight Needle	1
3	#24	301.12-03	绷针横轴	Stretch Tight Needle Crossing Shaft	1
4	#24	301.12-04	绷针下摆杆	Lower Oscillating Bar	1
5	#24	301.12-05	绷针连杆	Stretch Tight Needle Link Lever	1
6	#24	301.12-06	绷针曲柄	Stretch Tight Needle Crank	1
7	#12	301.12-07	绷针连接柱	Stretch Tight Needle Connecting Pole	1
8	#24	301.12-08	绷针上摆杆	Upper Oscillating Bar	1
9	#24	301.12-09	摆杆螺钉	Oscillating Bar Screw	1
10	#24	301.12-10	绷针调节摆杆	Regulate Oscillating Bar	1
11	#24	301.12-11	绷针凸轮	Stretch Tight Needle Cam	1
12	#24	21-05212121-03	垫圈	Washer	1
13	#04、#20	32-09440190-09	骨架 油封	O-ring	1
14	#20	301.12-14	绷针竖套	Stretch Tight Needle Upright Bushing	1
15	#24	21-12114152-03	垫圈	Washer	1
16	#24	301.12-16	绷针左套	Stretch Tight Needle Left Bushing	1
17	#24	301.12-17	绷针紧圈	Thrust Ring	1
18	#24	301.12-16	绷针右套	Stretch Tight Needle Right Bushing	1
19	#24	12-40401025-01	螺钉	Screw	1
20	#24	14-60504020-01	螺母	Nut	1
21	#24	12-85600512-01	螺钉	Screw	2
22	#24	12-65601422-01	螺钉	Screw	1
23	#24	12-80500512-01	螺钉	Screw	2
24	#24	11-40080425-01	螺钉	Screw	2
25	#24	12-40401425-01	螺钉	Screw	1
26	#24	21-10220232-03	垫圈	Washer	1
27	#24	31-10020000-09	O型圈	Rubber Ring	1

Note:
#04...For -02HY不用
#20...For -4、-21不用
#24...For -4、-02HY不用

13. 过线器部件 THREAD GUIDE MECHANISM COMPONENTS

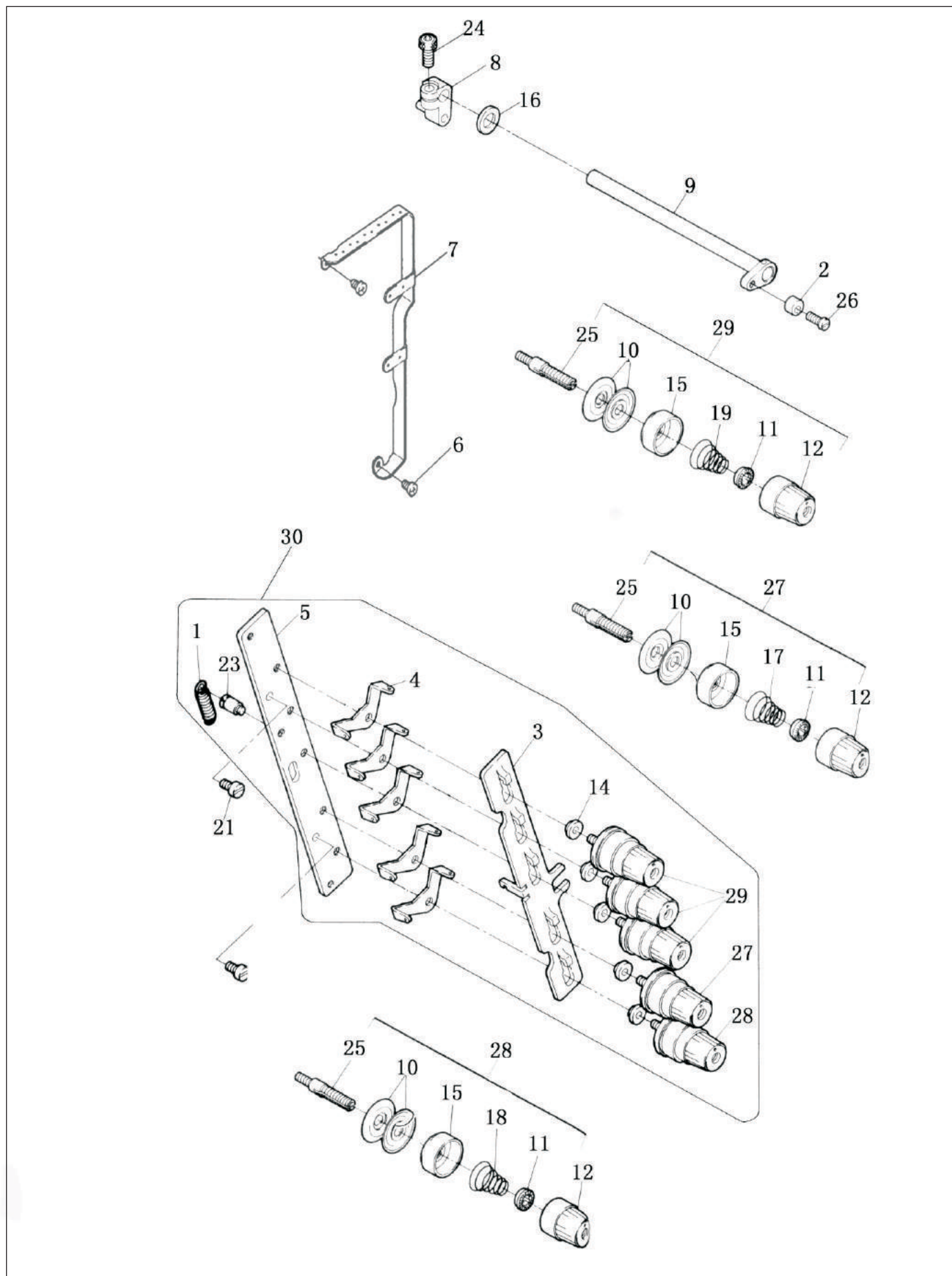

13. 过线器部件 THREAD GUIDE MECHANISM COMPONENTS

序号 NO.	注解 NOTE	图号 REF NO.	名称	DESCRIPTION	数量 AMT
1		301.13-01	挺线板拉簧	Spring	(1)
2	#01	301.13-02	隔套	Spacer	1
3	#25	301.13-03	过线座	Thread Eyelet Base	(1)
	#16	312.13-03	过线座	Thread Eyelet Base	(1)
4		301.13-04	压线过线板2	Thread Guide Plate2	(5)
5	#12、#25	301.13-05	挺线板	Thread Eyelet Base	(1)
	#16	312.13-05	挺线板	Thread Eyelet Base	(1)
6	#12	12-40400525-01	螺钉	Screw	2
7	#12、#25	340.13-07	过线架	Thread Eyelet Stand	1
	#16	312.13-07	过线架	Thread Eyelet Stand	1
8	#01	301.13-08	挺线杆曲柄	Thread Eyelet Base Shaft Crank	1
9	#01	301.13-09	挺线杆(组件)	Thread Eyelet Base Shaft	1
	#01	301.13-09-01	挺线杆轴	Thread Eyelet Base Shaft	(1)
	#01	301.13-09-02	挺线杆曲柄	Thread Eyelet Base Crank	(1)
10		301.13-10	夹线板	Thread Tension Plate	(10)
11		301.13-11	夹线防松圈	Thread Tension Ring	(5)
12		301.13-12	夹线螺母	Thread Tension Nut	(5)
14		301.13-14	垫圈	Washer	(5)
15		301.13-15	夹线座	Thread Tension Base	(5)
16		21-08220151-01	垫圈	Washer	1
17		301.13-17	夹线簧	Thread Tension Spring	(1)
18		301.13-18	夹线簧	Thread Tension Spring	(1)
19		301.13-19	夹线簧	Thread Tension Spring	(3)
21		12-40400825-01	螺钉	Washer	2
23		301.13-23	挺线板螺钉	Screw	(1)
24	#01	12-60501222-01	螺钉	Screw	1
25		301.13-25	夹线螺钉	Thread Tension Screw Stud	(5)
26	#01	11-40111225-01	螺钉	Screw	1
27		301.13-27	夹线器组件B	Thread Tension Spring Arm B	(1)
28		301.13-28	夹线器组件C	Thread Tension Spring Arm C	(1)
29		301.13-29	夹线器组件A	Thread Tension Spring Arm A	(3)
30		343.13-10	夹线器大组件	Thread Tension Spring Arm.	1

Note:
 #01...For -7不用
 #12...For -21不用
 #16...For -6专用
 #25...For -6不用

14. 过线部件 THREAD GUIDE COMPONENTS

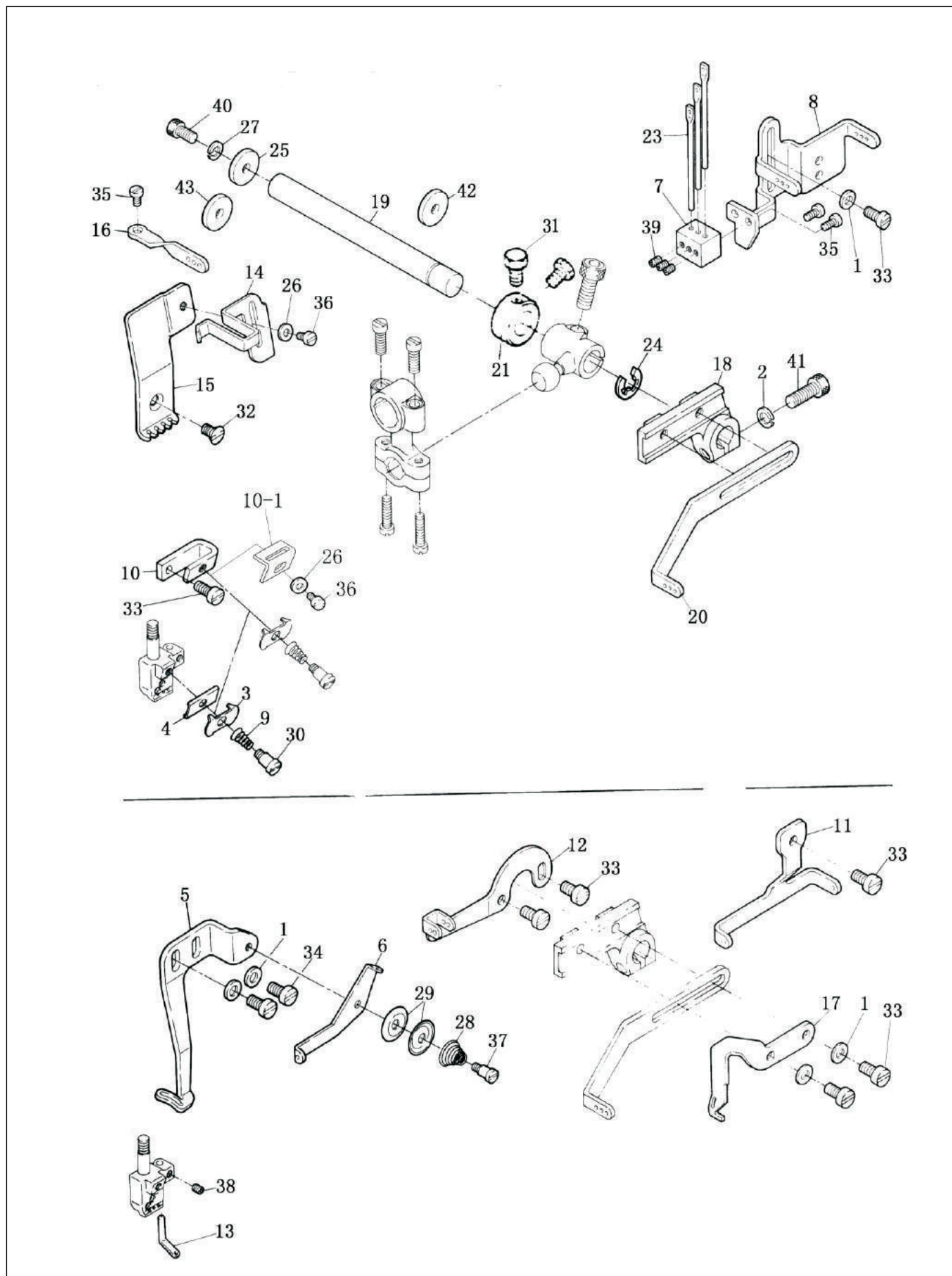

14. 过线部件 THREAD GUIDE COMPONENTS

序号 NO.	注解 NOTE	图号 REF NO.	名称	DESCRIPTION	数量 AMT
1	#04	21-04308090-02	垫圈	Washer	5
2	#04	22-05000000-08	垫圈	Washer	1
3		301.14-03	针轧过线压板	Thread Guide Pressing Plate	1
4		301.14-04	针轧过线板	Thread Guide Plate	1
5	#12、#24	301.14-05	绷线过线下过线板	Lower Thread Guide Plate	1
6	#24	301.14-06	绷线过线板	Thread Guide Plate	1
7	#25	301.14-07	硅油过线座	Silicone Thread Guide Base	1
	#16	312.14-07	硅油过线座	Silicone Thread Guide Base	1
8	#25	301.14-08	硅油过线座	Silicone Thread Guide Base	1
	#16	312.14-08	硅油过线座	Silicone Thread Guide Base	1
9		301.14-09	针轧过线簧	Thread Eyelet Spring	1
10		301.14-10	小过线座	Thread Guide Base (small)	1
		301.14-10-01	挡线板	Block The Line Plank	1
11	#24	301.14-11	绷线上导线板	Upper Thread Guide Plate	1
12	#19	301.14-12	张线杆	Thread Eyelet Guide Lever	1
13	#24	301.14-13	针轧右过线杆	Thread Eyelet Right Bar	1
14		301.14-14	挑线防护罩	Thread Take-up Shield	1
15		301.14-15	挑线防护罩座	Thread Take-up Shield Base	1
16		301.14-16	针杆上过线	Needle Bar Top Thread Guide	1
17		301.14-17	上叉挑线杆	Thread Take-up Lever	1
18		301.14-18	挑线杆座	Thread Take-up Lever Base	1
19		301.14-19	挑线杆轴	Thread Take-up Lever Shaft	1
20	#25	301.14-20	挑线杆	Thread Take-up Lever	1
	#16	312.14-20	挑线杆	Thread Take-up Lever	1
21		301.14-21	紧圈	Thrust Ring	1
23		301.14-23	挑线钉	Thread Eyelet Guided Nail	3
24		24-07000000-09	开口挡圈	Snap Ring	1
25		21-04520141-01	垫圈	Washer	1
26		21-03208070-02	垫圈	Washer	2
27		22-04000000-08	止退圈	Stopper Ring	1
28	#24	301.14-28	压线簧	Presser Spring	1
29	#24	279.04-58	过线板	Presser Plate	2
30		301.14-30	针轧过线螺钉	Screw	1
31		11-00110620-01	螺钉	Screw	2
32		12-10400820-01	螺钉	Screw	1
33	#04	12-40400825-01	螺钉	Screw	7
34	#12、#24	12-40400825-01	螺钉	Screw	2
35		12-40300625-01	螺钉	Screw	3
36		12-60300420-01	螺钉	Screw	2
37	#12、#24	301.14-37	夹线螺钉	Screw	1
38	#19	12-80300312-01	螺钉	Screw	1
39		12-80300412-01	螺钉	Screw	3
40		12-60400822-01	挑线杆轴螺钉	Thread Take-up Lever Shaft Screw	1
41		12-60501622-01	螺钉	Screw	1
42		301.08-20	挑线杆轴前套	Thread Take-up Lever Shaft Front Bushing	1
43		301.14-43	挑线杆轴后套	Thread Take-up Lever Shaft Back Bushing	1

Note:
 #04...For -02HY不用
 #12...For -21不用
 #16...For -6专用
 #19...For -4不用
 #24...For -4、-02HY不用
 #25...For -6不用

15. 下过线器部件 LOWER THREAD TENSION COMPONENTS

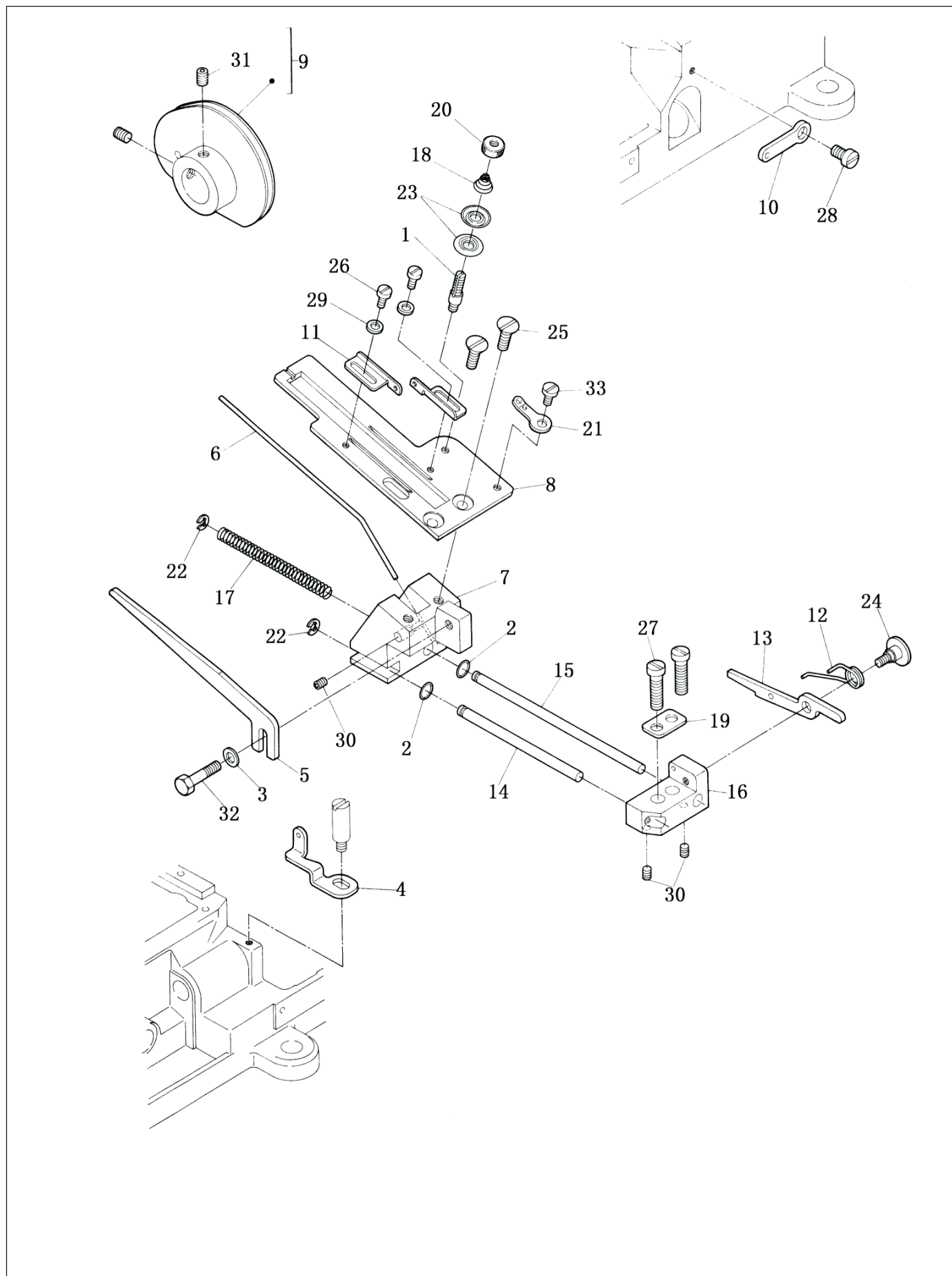

15. 下过线器部件 LOWER THREAD TENSION COMPONENTS

序号 NO.	注解 NOTE	图号 REF NO.	名称	DESCRIPTION	数量 AMT
	#26	301.15-00	打线器组件		1
1	#26	209.19-11	压线板螺钉	Screw	(1)
2	#26	31-05020000-09	O型垫圈	O-ring	(2)
3	#26	21-04308090-02	垫圈	Washer	(1)
4		301.15-04	过线板	Thread Guide Plate	1
5	#26	301.15-05	下过线压板	Lower Thread Guide Presser Plate	(1)
6	#26	301.15-06	下过线杆	Lower Thread Eyelet Bar	(1)
7	#26	301.15-07	下过线架	Lower Thread Guide Frame	(1)
8	#26	301.15-08	下过线板	Lower Thread Guide Plate	(1)
9	#26	301.15-09	凸轮 (组件)	Cam Asm.	1
	#26	301.15-09-01	绕线凸轮	Round The Line Cam	(1)
	#26	301.15-09-02	凸轮衬套	Cam Bushing	(1)
	#26	301.15-09-03	打线凸轮垫圈	Washer	(1)
10	#19	301.15-10	过线板	Thread Guide Plate	1
11	#19、#26	301.15-11	下过线板	Lower Thread Guide Plate	(2)
12	#26	301.15-12	下过线勾	Lower Thread Finger	(1)
13	#26	301.15-13	扳手	Handle	(1)
14	#26	301.15-14	下线短导杆	Short Thread Leader Rod	(1)
15	#26	301.15-15	下过线导杆	Thread Leader Rod	(1)
16	#26	301.15-16	下过线座	Lower Thread Guide Seating	(1)
17	#26	301.15-17	压簧	Press Spring	(1)
18	#26	209.19-13	绷线簧	Spring	(1)
19	#26	301.15-19	下过线垫片	Washer	1
20	#26	209.19-14	螺母 (夹线板专用)	Nut	(1套)
21	#26	301.15-21	下过线板	Lower Thread Guide Plate	(1)
22	#26	301.15-22	开口挡圈	Snap Ring	(2)
23	#26	209.19-12	绷线小压板	Presser Plate	(2)
24	#26	301.15-24	螺钉	Screw	(1)
25	#26	12-10400820-01	螺钉	Screw	(2)
26	#26	12-60250420-01	螺钉	Screw	(2)
27	#26	12-40401625-01	螺钉	Screw	2
28		12-40400625-01	螺钉	Screw	1
29	#26	21-02705060-01	垫圈	Washer	(2)
30	#26	12-80300312-01	螺钉	Screw	(3)
31	#26	12-80500512-01	螺钉	Screw	2
32	#26	12-90400620-01	螺钉外六角	Screw	(1)
33	#26	12-60300420-01	螺钉	Screw	(1)

Note:
#19...For -4不用
#26...For 500-01不用

16. 供油部件 LUBRICATION MECHANISM COMPONENTS

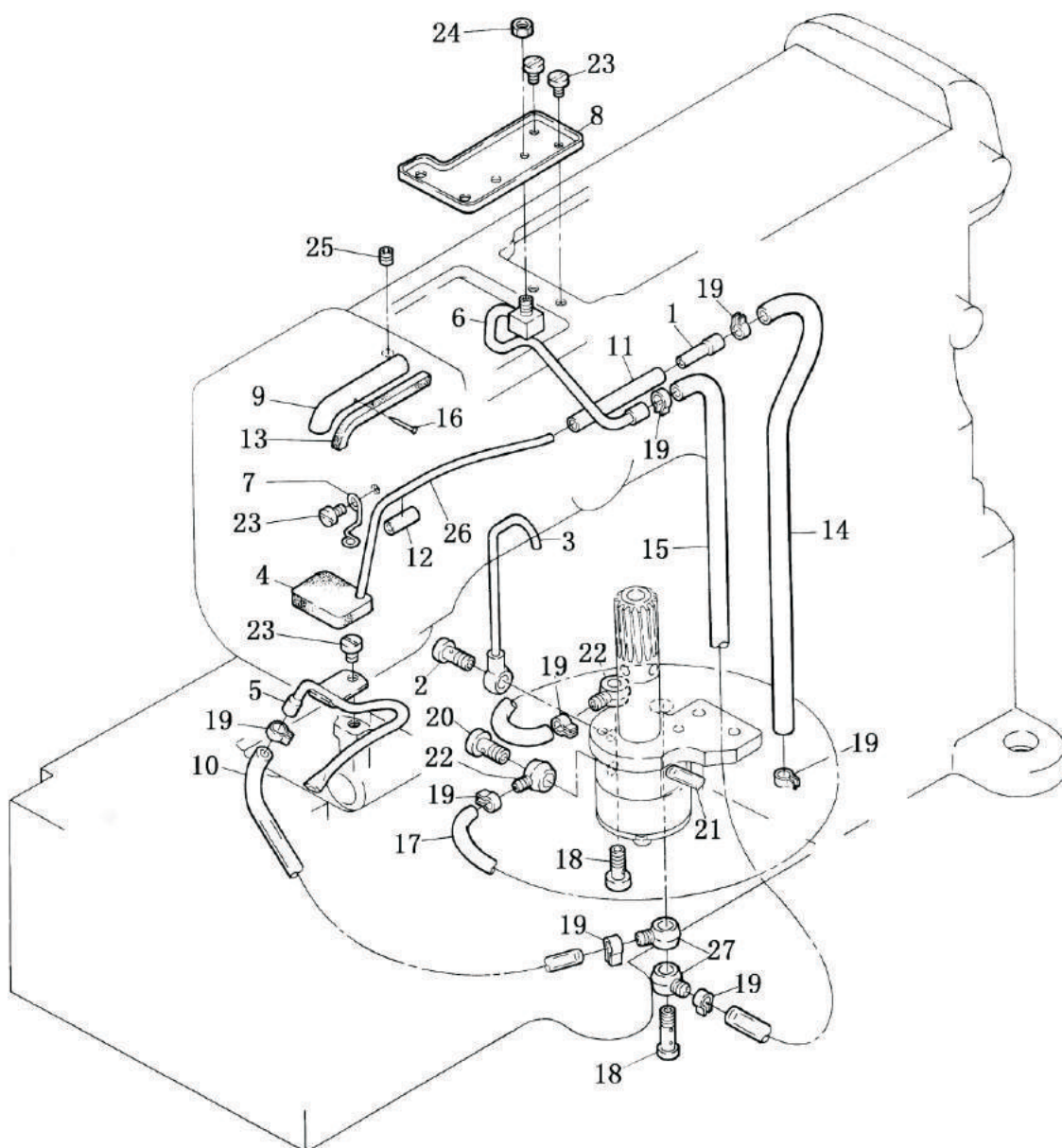

16. 供油部件 LUBRICATION MECHANISM COMPONENTS

序号 NO.	注解 NOTE	图号 REF NO.	名称	DESCRIPTION	数量 AMT
1		301.16-01	管接头	Terminal	1
2		301.16-02	螺钉小双通油接头	Screw With Small Double Holes	1
3		301.16-03	油管组件	Oil Tube Complete	1
4		301.16-04	羊毛毡	Wool Felt	1
5		301.16-05	下油管组件	Lower Oil Tube Complete	1
6		301.16-06	油管组件	Oil Tube Complete	1
7		301.16-07	油管定位勾	Oil Tube Holder	1
8	#04	301.16-08	上油盘	Upper Oil Pan	1
9		301.16-09	油管	Oil Tube	1
10		42-07005000-00	油管5×7×260	Oil Tube 5×7×260	0.26
11		301.16-11	油管	Oil Tube	1
12		42-05003000-00	小油管3×5×40	Small Oil Tube 3×5×40	0.04
13		43-10300000-00	油线	Oil Wick	1
14		42-07005000-00	油管5×7×310	Oil Tube 5×7×310	0.31
15		42-07005000-00	油管5×7×400	Oil Tube 5×7×400	0.4
16		301.16-16	油线钉	Oil Wick Nail	1
17		42-07005000-00	油管5×7×190	Oil Tube 5×7×190	0.19
18		301.16-18	螺钉双通油接头	Screw With Double Holes	2
19		301.16-19	夹头	Collet	2
20		301.16-20	螺钉单通油螺钉	Screw With Single Hole	1
21		301.16-20-01	管接头	Terminal	1
22		301.16-21	管接头(单)	Terminal (Single Hole)	2
23		12-40400625-01	螺钉	Screw	4
24		14-60403020-01	螺母	Nut	1
25		12-80500512-01	螺钉	Screw	1
26		301.16-25	油管	Oil Tube	1
27		301.16-26	管接头(双)	Terminal	1
28		301.16-19-02	夹头(中)		6

Note:
#04...For -02HY不用

17. 油泵部件 PUMP COMPONENTS

序号 NO.	注解 NOTE	图号 REF NO.	名称	DESCRIPTION	数量 AMT
1		301.17-01	(油泵组件)	Pump Complete	1
2		301.17-02	油泵连接板	Fixing Plate	(1)
3		301.17-03	油泵端盖(底板)	Motherboard	(1)
4		301.17-04	内齿轮	Inner Gear Wheel	(2)
5		301.17-05	上齿轮	Gear Wheel (upper)	(1)
6		301.17-06	下齿轮	Gear Wheel (lower)	(1)
7		301.17-07	油示轴	Shaft	(1)
8		301.17-08	油泵壳体	Pump Body	(1)
9		301.17-09	上油泵体	Upper Pump Body	(1)
10		301.17-10	油泵蜗轮	Small Gear Wheel	(1)
11		343.17-08	油盘防油垫	Oil Protecting Gasket	1
12		301.17-12	油盘组件	Oil Pan Asm.	1
13		301.17-13	油盘	Oil Pan	1
14		301.17-14	滤油器盖	Pump Filter Cover	1
15		301.17-15	滤油器螺钉	Pump Filter Screw	1
16		31-39035000-09	O型圈	O-ring	1
17		279.08-23	纸质滤油器	Pump Filter	1
18		301.17-18	密封垫	Oil Protecting Gasket	1
19		301.17-20	螺钉	Screw	(2)
20		301.17-21	螺钉	Screw	(2)
21		12-40401225-01	螺钉	Screw	3
22		301.17-23	油盘螺钉	Oil Pan Screw	1
23		12-60501222-01	螺钉	Screw	2
24		12-80500512-01	螺钉	Screw	(2)
25		12-60802022-01	螺钉	Screw	5
26		44-00000008-00	商标	Brand	1

18. 机针冷却器部件 NEEDLE COOLING MECHANISM COMPONENTS

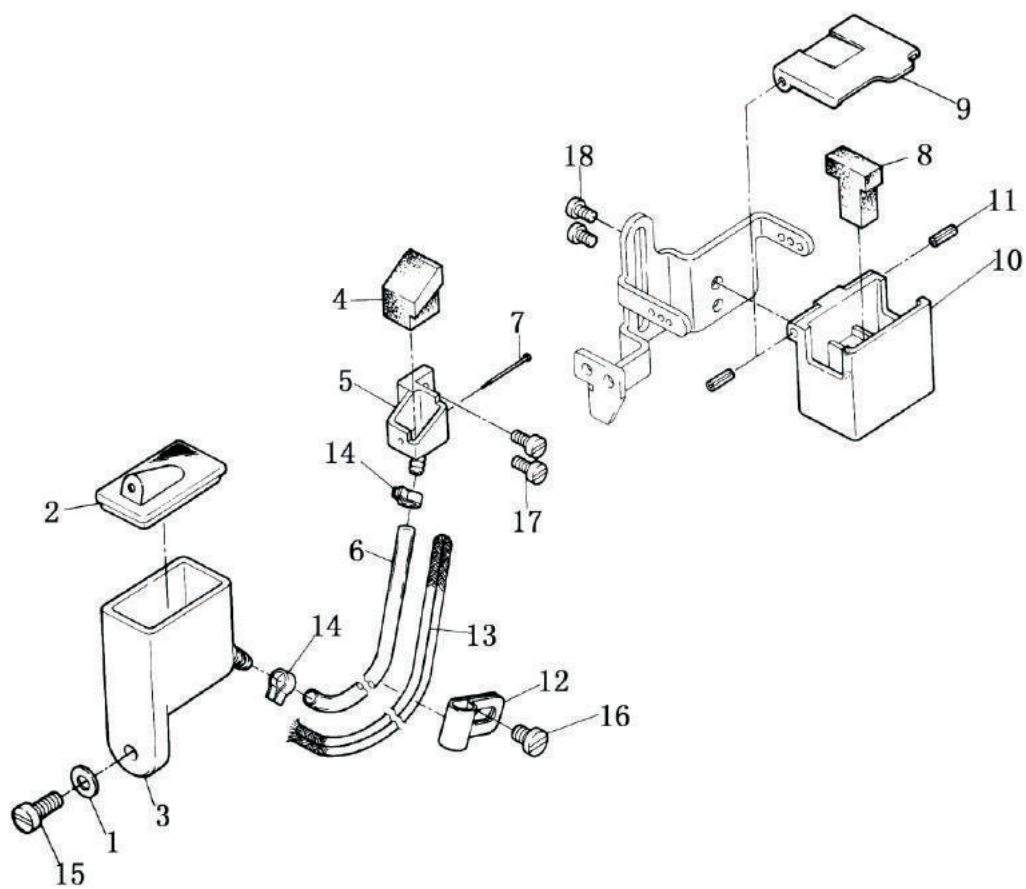

18. 机针冷却器部件 NEEDLE COOLING MECHANISM COMPONENTS

序号 NO.	注解 NOTE	图号 REF NO.	名称	DESCRIPTION	数量 AMT
1	#19	21-04308090-02	垫圈	Washer	1
2	#19	301.18-02	硅油储盒盖	Silicone Oil Reservoir Cover	1
3	#19	301.18-03	硅油储盒	Silicone Oil Reservoir	1
4	#19	301.18-04	硅油盒油毡	Silicone Oil Reservoir Felt	1
5	#19	301.18-05	硅油盒壳体	Silicone Oil Reservoir Body	1
6	#19	42-07005000-00	硅油输油管	Silicone Oil Efferent	0.135
7	#19	279.09-20	大头针	Pin	1
8		301.18-08	上硅油毡	Silicone Oil Felt (upper)	1
9		301.18-09	上硅油盖	Silicone Oil Cover (upper)	1
10		301.18-10	上硅油盒	Silicone Oil Case (upper)	1
11		41-20200500-00	开口弹簧销 $\phi 2 \times 5$	Elastic Pin $\phi 2 \times 16$	2
12	#19	301.18-12	油线压板	Oil Wick Press Plate	1
13	#19	43-10250000-00	油线	Oil Wick	0.27
14	#19	301.16-19-01	弹簧管夹头(小)	Spring Tube Collet	2
15	#19	12-40401025-01	螺钉	Screw	1
16	#19	12-40400625-01	螺钉	Screw	1
17	#19	12-40300625-01	螺钉	Screw	2
18		11-40090525-01	螺钉	Screw	2

Note:
#19...For -4不用

19. 线架部件 THREAD STAND COMPONENT

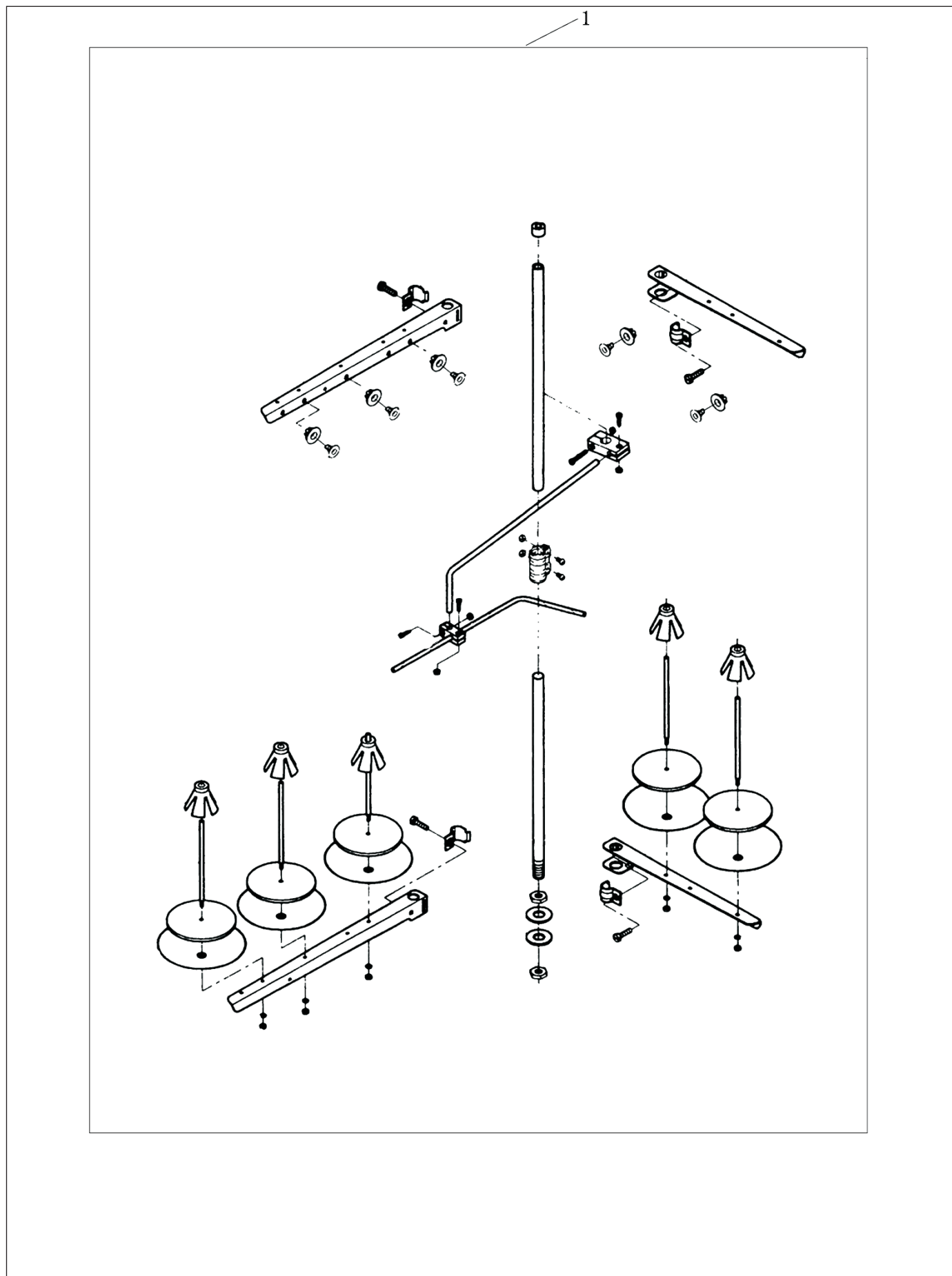

19. 线架部件 THREAD STAND COMPONENT

序号 NO.	注解 NOTE	图号 REF NO.	名称	DESCRIPTION	数量 AMT
1	#19、#25 #16 #27	279. 12-05 279. 12-06 279. 12-04	五线线架组件 六线线架组件 四线线架组件	Thread Stand Complete. Thread Stand Complete. Thread Stand Complete.	1 1 1
				<p>Note: #16...For -6专用 #19...For -4不用 #25...For -6不用 #27...For -4专用</p>	

20. 附件 ACCESSORIES PARTS

序号 NO.	注解 NOTE	图号 REF NO.	名称	DESCRIPTION	数量 AMT
1		301.20-01	承重板	Bearing Plate	2
2		301.20-02	胶垫	Space Ring	4
3		21-08515260-01	垫片	Washer	12
4		301.20-04	螺钉	Screw	4
5		301.20-05	护板	Protect Plate	1
6		301.20-06	胶垫骨架	Space Ring Frame Work	4
7		301.20-07	胶垫	Space Ring	4
8		301.20-08	塑料垫圈	Plastic Washer	4
9		301.20-09	螺钉	Screw	4
10		12-40500825-01	螺钉	Screw	2
11		12-60805522-01	长螺钉	Long Screw	4
12		301.20-13	内六角 S2	Within Six Foreland (2-6)	1
		301.20-15	内六角 S2.5		1
		301.20-26	内六角 S3		1
		301.20-27	内六角 S3.5		1
		301.20-28	内六角 S4		1
		301.20-29	内六角 S5		1
		301.20-30	内六角 S6		1
13		279.11-29	S1.5有柄内六角扳手	Hexagon Wrench S1.5	1
14		279.11-22	双头板手S8	Two-head Driver(S7、S8)	1
		279.11-22B	双头板手S7		1
15		279.11-24	小镊子	Tweezer	1
16		279.11-17	圆塑料漏斗	Filler	1
17		279.11-12	抬压脚链条	Chain	1
		279.11-11	链条勾		2
18		101.12-21	油壶	Oil Bottle	1
19		279.11-18	小油壶	Small Oil Bottle	1
20		279.11-15	螺丝刀(大)	Screw Driver (L)	1
21		279.11-15A	螺丝刀(中)	Screw Driver (M)	1
22		279.11-19	硅油壶	Oil Tang	1
23		301.06-24	机针	Needle	3
24		279.08-23	纸质滤油器	Pump Filter	1
25		301.20-20	大尼龙袋		1
26	#01	301.20-21	外箱(宝石) 61×40×61.5		1
	#28	301.20-21-1	外箱(宝石) 61×40×61.5		1
27	#01	301.20-22	附件箱59×38×7		1
	#28	301.20-22-1	附件箱59×38×7		1
28	#01	301.20-23	身桶59.5×38.5×49.5		1
	#28	301.20-23-1	身桶59.5×38.5×49.5		1
29	#01	301.20-31	泡沫组件		1
	#28	301.20-34	泡沫组件		1
30		301.20-32	说明书	Operation Instruction & Parts Book	1
		301.20-33	零件样本		1
31		44-00000011-00	合格证		1

Note:
#01...For -7不用
#28...For -7专用

21. 导布部件 FABRIC GUIDE COMPONENTS

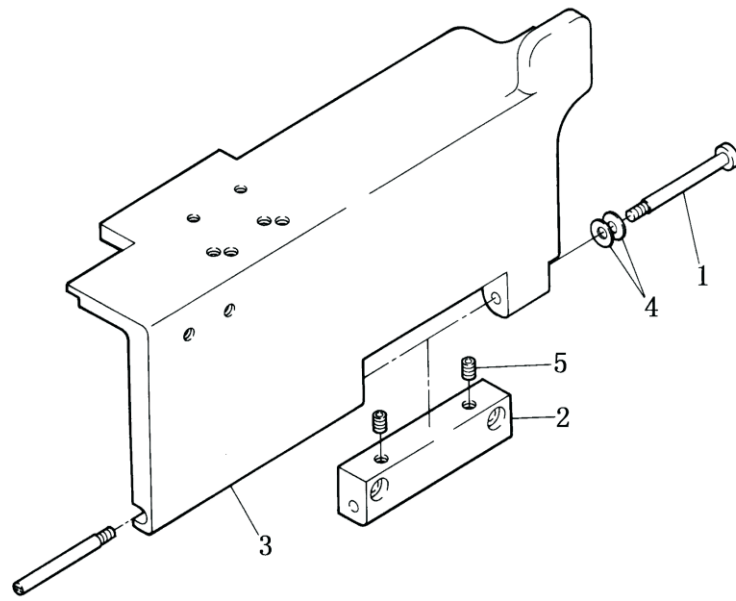

21. 导布部件 FABRIC GUIDE COMPONENTS

序号 NO.	注解 NOTE	图号 REF NO.	名称	DESCRIPTION	数量 AMT
1		301.02-13	长螺钉	Long Screw	1
2	#29	301.21-03	穿线链	Hinge Thread Guide Lath	1
3	#05、#29	301.21-04	穿线罩板	Thread Guide Plate	1
4		22-05000000-08	鞍形垫圈	Wave Washer	2
5		12-80500612-01	螺钉	Screw	2

Note:
 #05...For -5、-4不用
 #29...For -2、-02HY、-02DN、-02QG不用

22. (500B-02/02HY/02QG/02DN)专用部件
SPECIFIC PARTS (FOR 500B-02/02HY/02QG/02DN)

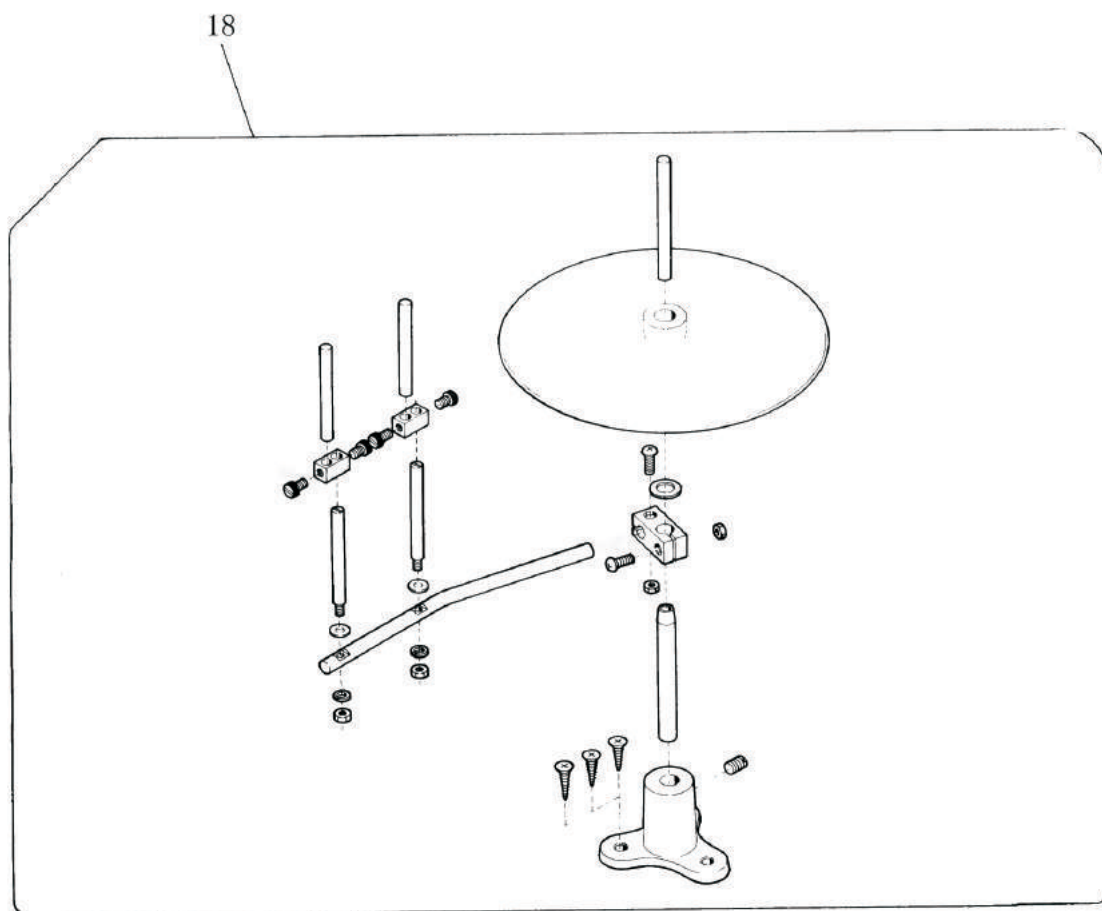
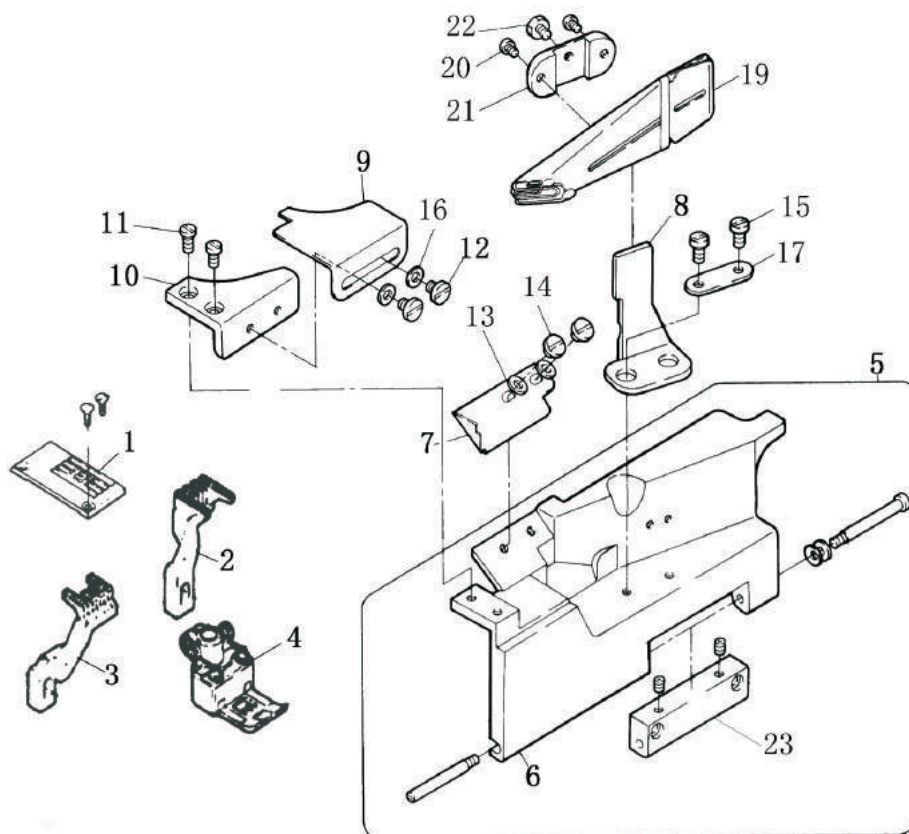

22. (500B-02/02HY/02QG/02DN)专用部件

SPECIFIC PARTS (FOR 500B-02/02HY/02QG/02DN)

序号 NO.	注解 NOTE	图号 REF NO.	名称	DESCRIPTION	数量 AMT
1		302.06-01	针板	Needle Plate	1
		302.06-01(6.4)	针板(6.4)	Needle Plate	1
2		302.09-01	主送布牙	Main Feed Dog	1
3		302.09-02	差动送布牙	Differential Feed Dog	1
4		302.11-00	压脚组件	Presser Foot Complete. (6.4)	1
		302.11-00(6.4)	压脚组件(6.4)	Presser Foot Complete.	1
		302.11-01	压脚柄	Presser Foot Handle	(1)
		302.11-02	压脚底板	Presser Foot Scaleboard	(1)
		302.11-03	压脚护板	Presser Foot Protect The Plank	(1)
		302.11-04	压脚连接柱	Pin	(1)
		302.11-05	压脚扭簧	Presser Foot Spring	(1)
		302.11-06	压脚扭簧螺钉	Screw	(1)
		302.11-07	压脚连接柱螺钉	Screw	(1)
		302.11-08	压脚销	Pin	(1)
		302.11-09	压脚压簧	Presser Foot Presser Spring	(1)
		302.11-10	压脚螺钉	Screw	(1)
5		302.23-00	穿线罩板组件	Thread Guide Plate Cover Complete	1
6		302.23-01	穿线罩板	Thread Guide Plate Cover	1
7		302.23-02	穿线罩板滚条护板(右)	Protect Plate(right)	1
8		302.23-03	穿线罩板滚条挡板	Bibcock Installation Bracket	1
9		302.23-04	穿线罩板滚条护板(左)	Protect Plate(left)	1
10		302.23-05	穿线罩挡线压板	Keep Off Thread Press Plate	1
11		12-40500825-01	穿线罩挡线压板螺钉	Keep Off Thread Press Plate Screw	2
		12-10400820-01	活动穿线罩板螺钉	Screw	1
12		12-40500625-01	穿线罩板护板(左)螺钉	Protect Plate(left) Screw	2
13		21-04308090-02	垫片	Washer	2
14		12-40400625-01	滚条护板(右)螺钉	Protect Plate(right) Screw	2
15		12-40601025-01	穿线罩板滚条挡板螺钉	Bibcock Installation Bracket Screw	2
16		21-05310100-02	垫片	Washer	2
17		302.23-12	穿线罩板滚条挡板垫片	Bibcock Installation Bracket Washer	1
18		302.23-07	滚边盘组件	Thread Stand Complete	1
		302.23-07-01	线架托盘	Spool Rest	(1)
		302.23-07-02	线架安装座	The Line Installs	(1)
		302.23-07-03	托盘安装棒	The Tray Installs The Strick	(1)
		302.23-07-04	短过线棒	Short Over Line Strick	(4)
		302.23-07-05	短过线棒安装座	Install Of Short Over Line Strick	(2)
		302.23-07-06	线架安装棒	The Line Installs The Stick	(1)
		302.23-07-07	线架安装棒安装座	Install Of The Line Installs The Stick	(1)
		302.23-07-08	线架托盘垫片	Spool Rest Cushion	(1)
		302.23-07-09	线架安装座螺钉	Screw	(1)
		302.23-07-10	紧定螺钉	Screw	(2)
		302.23-07-11	线架安装棒螺钉	Screw	(6)
		302.23-07-12	木螺钉	Screw	(3)
19		302.23-08	龙头组件(夹边器组件)	Bibcock Complete	1
20		12-40350525-01	夹线器固定板螺钉	Bibcock Fixing Plate Screw	2
21		302.23-09	夹线器固定板	Bibcock Fixing Plate	1
22		12-60501222-01	螺钉	Screw	1
23		302.23-13	穿线链	Hinge Thread Guide Lath	1

23. (500B-05)专用部件(1) SPECIFIC PARTS (1)(FOR 500B-05)

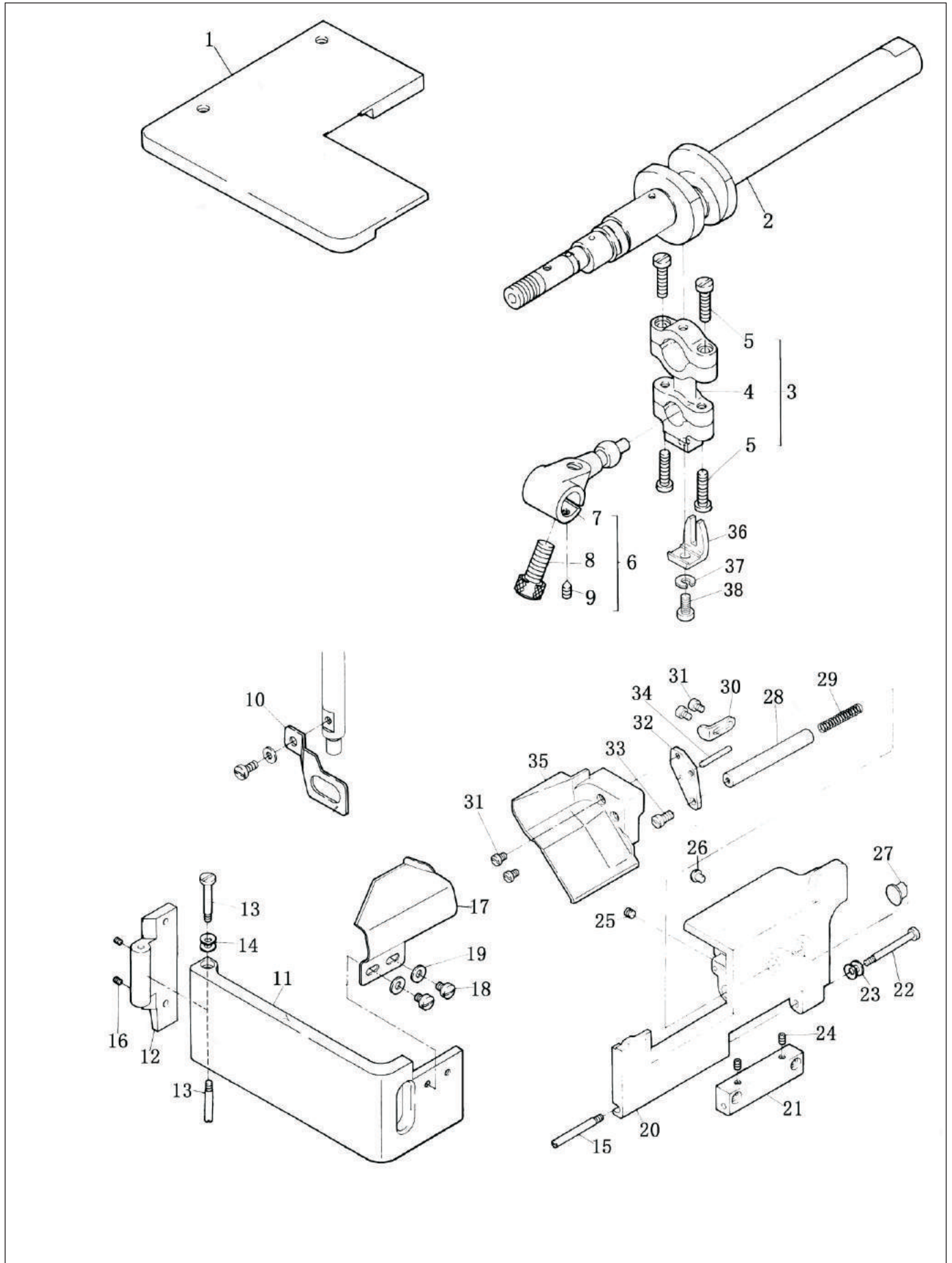

23. (500B-05)专用部件(1) SPECIFIC PARTS (1)(FOR 500B-05)

序号 NO.	注解 NOTE	图号 REF NO.	名称	DESCRIPTION	数量 AMT
1		311.24-01	缝台上盖	Sewing Plate Uper Cover	1
2		311.24-02	下轴前节	Lower Shaft Forepart	1
3		301.04-01	连杆组件	Looper Lever Complete Asm.	1
4		301.04-04	连杆	Looper Lever Complete	(1)
5		311.24-03-2	螺钉	Screw	(4)
6		311.24-04	曲柄组件	Looper Ball Crank Asm.	1
7		301.04-02	曲柄	Looper Ball Crank	1
8		12-65601422-01	螺钉	Screw	1
9		12-80300442-01	螺钉	Screw	1
10		311.24-05	护指架	Presser Bar Shield	1
11		311.24-06	左侧盖	Frontal Mantle	1
12		301.03-07	铰链	Hinge Board	1
13		301.03-06	螺钉	Hinge Link Screw	1
14		22-05000000-08	弹簧垫片	Spring Washer	2
15		301.02-01	销轴	Hinge Screw	1
16		12-80300412-01	螺钉	Screw	2
17		311.24-12	护料板	Protect Bat	1
18		12-40500625-01	螺钉	Secrew	2
19		21-05310100-02	垫圈	Washer	2
20		311.24-15	前盖	Frontal Mantle	1
21		301.21-03	铰链	Hinge Thread Guide Lath	1
22		301.02-13	螺钉	Long Screw	1
23		22-05000000-08	弹簧垫片	Wave Washer	2
24		12-80500512-01	螺钉	Screw	2
25		12-80500612-01	螺钉	Screw	1
26		301.02-17	孔塞	Shockproof Plug	1
27		311.24-23	塞子	Plug	1
28		311.24-24	轴	Shaft	1
29		311.24-25	弹簧	Spring	1
30		311.24-26	止动片	Stop Stir Piece	1
31		12-40400625-01	螺钉	Screw	2
32		311.24-28	支架	Bar Rock Shaft	1
33		12-40501025-01	螺钉	Screw	1
34		41-1030280000	销	Pin	1
35		311.24-31	前盖 (小)	Frontal Mantle (small)	1
36		301.04-22	叉口	Fork	1
37		22-05000000-08	开口垫圈	Snap Rign	1
38		11-90110820-01	叉口螺钉	Fork Screw	1

24. (500B-05)专用部件(2) SPECIFIC PARTS (2) (FOR 500B-05)

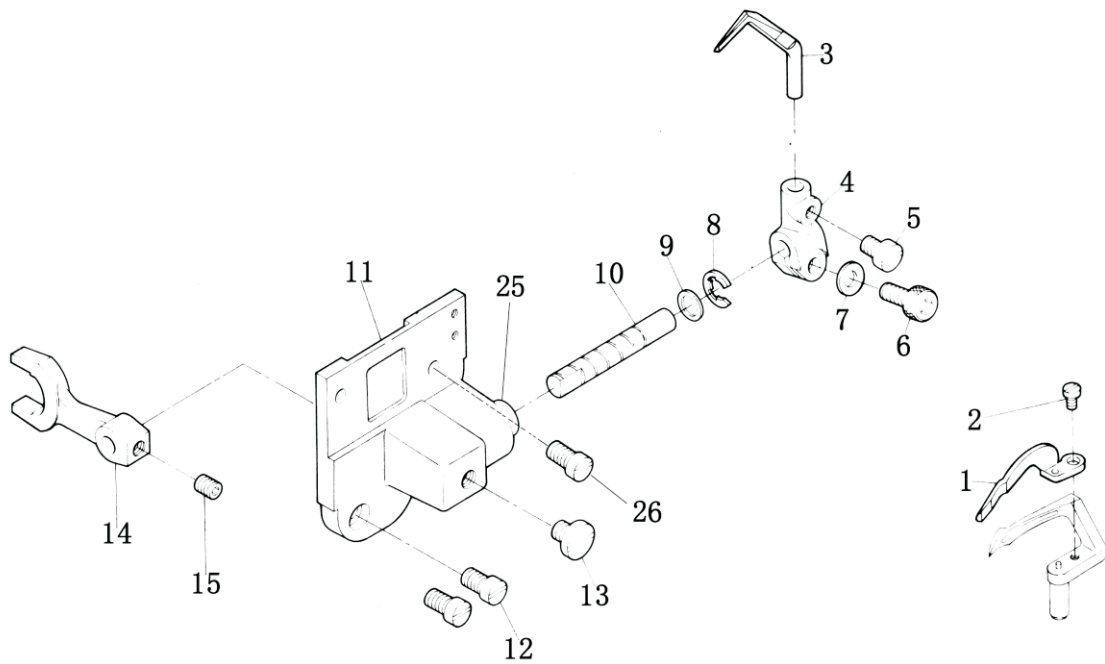

500B-05

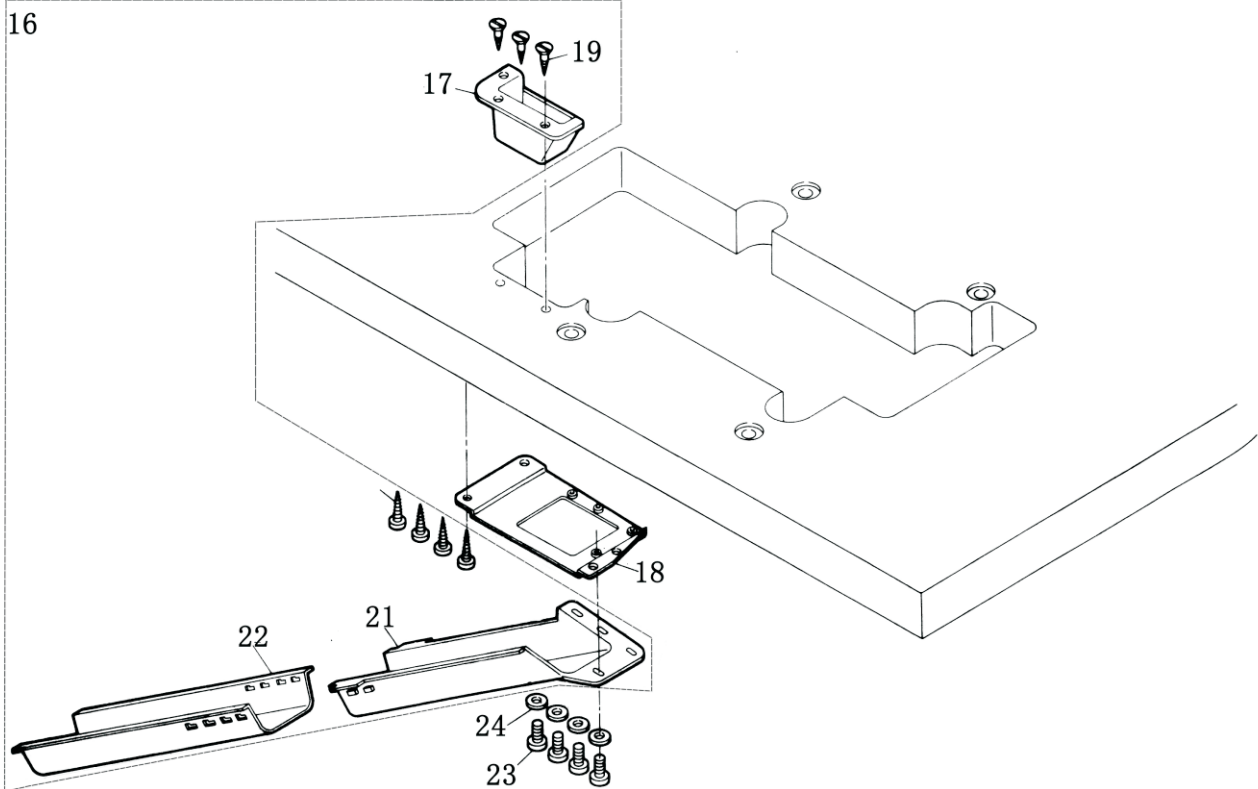

24. (500B-05)专用部件(2) SPECIFIC PARTS (2) (FOR 500B-05)

序号 NO.	注解 NOTE	图号 REF NO.	名称	DESCRIPTION	数量 AMT
1		301.07-21	护针 (前)	Front Needle Guard	1
2		12-40250425-01	螺钉	Screw	1
3		301.07-03	护针 (后)	Rear Needle Guard	1
4		311.25-04	杠杆	Hand Lifter Link	1
5		12-40400525-01	螺钉	Screw	1
6		12-60501022-01	螺钉	Screw	1
7		22-05000000-08	弹簧垫片	Washer	1
8		24-05000000-08	卡簧	Retaining Ring	1
9		21-06210101-01	垫圈	Washer	1
10		311.25-10	轴	Shaft	1
11		311.25-11	支架	Bar Rock Shaft	1
12		12-40400825-01	螺钉	Screw	2
13		12-60600420-01	螺钉	Screw	1
14		311.25-14	杠杆	Hand Lifter Link	1
15		12-80500512-01	螺钉	Screw	1
16		311.25-20	废料漏斗组件		1
17		311.25-16	废屑槽	Filler Chute	-1
18		311.25-18	支架	Bar Rock Shaft	1
19		311.25-19	螺钉	Screw	(7)
21		279.11-09	废屑流槽	Filler Chute (upper)	(1)
22		279.11-10	废屑流槽	Filler Chute(lower)	(1)
23		12-40401225-01	螺钉	Screw	4
24		21-04308090-02	垫圈	Washer	4
25		311.25-23	铜套	Copper Bushing	1
26		12-70400820-01	螺钉	Screw	1

25. (500B-05)专用部件(3) SPECIFIC PARTS (3) (FOR 500B-05)

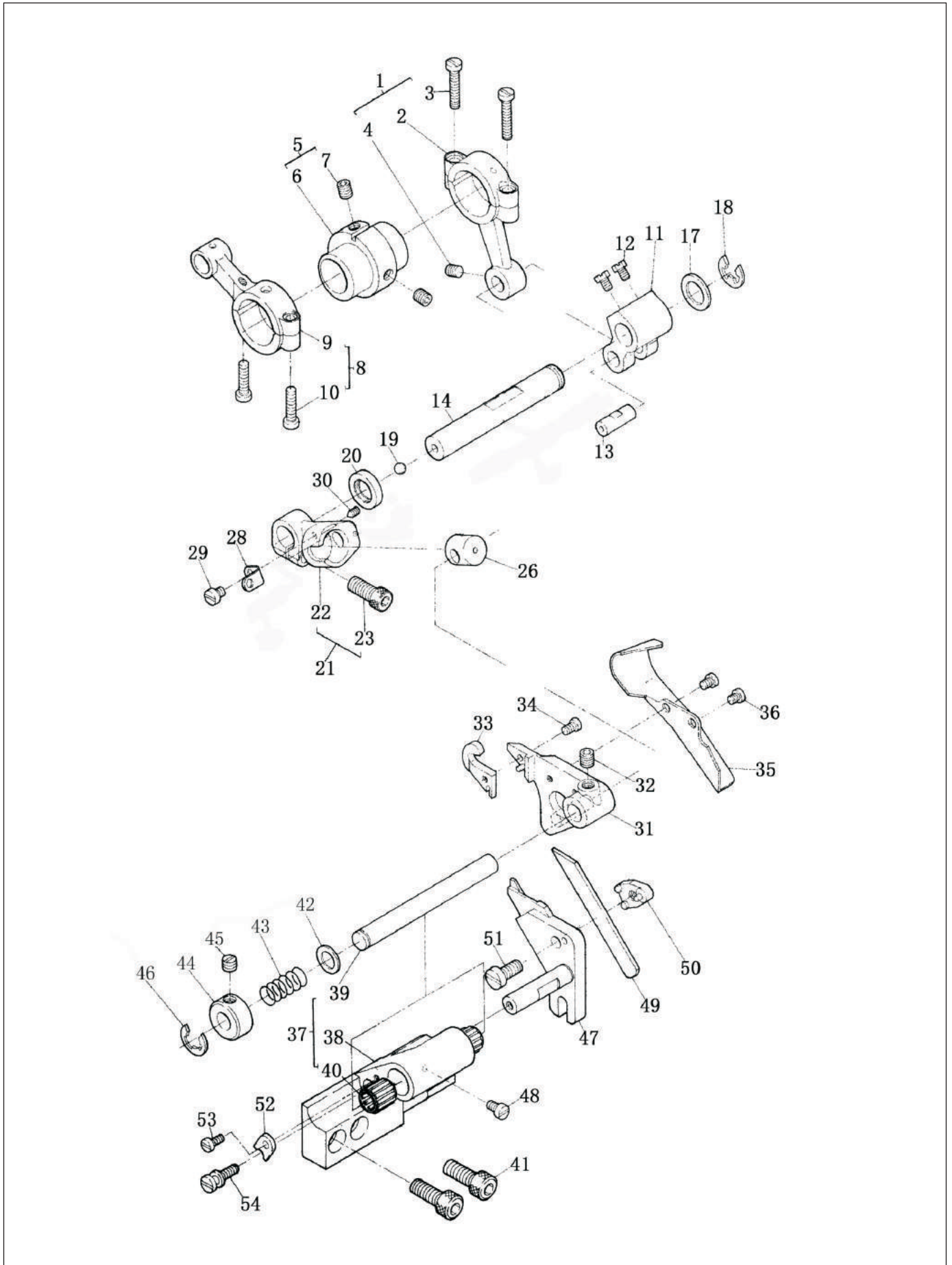

25. (500B-05)专用部件(3) SPECIFIC PARTS (3) (FOR 500B-05)

序号 NO.	注解 NOTE	图号 REF NO.	名称	DESCRIPTION	数量 AMT
1		301.07-04	连杆组件	Connecting Rod Asm.	1
2		301.07-04	连杆	Connecting Rod	(1)
3		11-40111425-01	螺钉	Screw	(2)
4		12-80400412-01	螺钉	Screw	1
5		311.26-02	偏心轮组件	Eccentric Cam Asm.	1
6		311.26-02-1	偏心轮	Eccentric Cam	1
7		12-80500612-01	螺钉	Screw	2
8		301.08-17	连杆组件	Looper Link Lever Asm.	1
9		301.08-17	连杆	Looper Link Lever	(1)
10		11-40091425-01	螺钉	Screw	(2)
11		301.07-01	曲柄	Needle Guard Crank	1
12		11-90110820-01	螺钉	Screw	2
13		301.07-10	销	Pin	1
14		311.26-07	轴	Shaft	1
17		21-10212142-01	垫圈	Washer	1
18		24-07000000-09	卡簧	Snap Thrust Ring	1
20		32-09430150-09	油封	Oil Seal	1
21		311.26-14	杠杆组件	Hand Lifter Link Asm.	1
22		311.26-14-1	杠杆	Hand Lifter Link	1
23		12-60501622-01	螺钉	Screw	1
26		311.26-17	滑块	Slide Block	1
28		311.26-19	销门	Pin	1
29		12-40300625-01	螺钉	Screw	1
30		12-80300442-01	螺钉	Screw	1
31		311.26-22	上切刀架	Upper Knife Bracket Asm.	1
		311.26-22-01	销	Pin	(1)
32		12-85600512-01	螺钉	Screw	1
33		311.26-24	上切刀	Upper Knife Bracket	1
34		11-60080620-01	螺钉	Screw	1
35		311.26-26	挡屑罩	Ward Off Scraps Cover	1
36		12-60300420-01	螺钉	Screw	2
37		311.26-28	支架组件	Bar Rock Shaft Asm.	1
38		311.26-28-1	支架	Bar Rock Shaft	1
39		311.26-28-2	轴	Shaft	1
40		311.26-28-3	滚针轴承	Needle Bearing	2
41		12-60601422-01	螺钉	Screw	2
42		21-08210162-03	垫圈	Washer	1
43		311.26-31	弹簧	Spring	1
44		301.11-21	紧圈	Thrust Ring	1
45		11-80110410-01	螺钉	Screw	1
46		24-06000000-08	卡簧	Clip Spring	1
47		311.26-35	下切刀架	Knife Bottom Bracket	1
48		12-40400625-01	螺钉	Screw	1
49		209.11-19	下刀片	Knife Bottom	1
50		311.26-38	下刀夹	Knife Bottom	1
51		12-40501025-01	螺钉	Screw	1
52		311.26-40	导向器	Lead Faver Ware	1
53		12-40300625-01	螺钉	Screw	1
54		311.26-42	螺钉	Screw	1

26. (500B-05)专用部件(4) SPECIFIC PARTS (4) (FOR 500B-05)

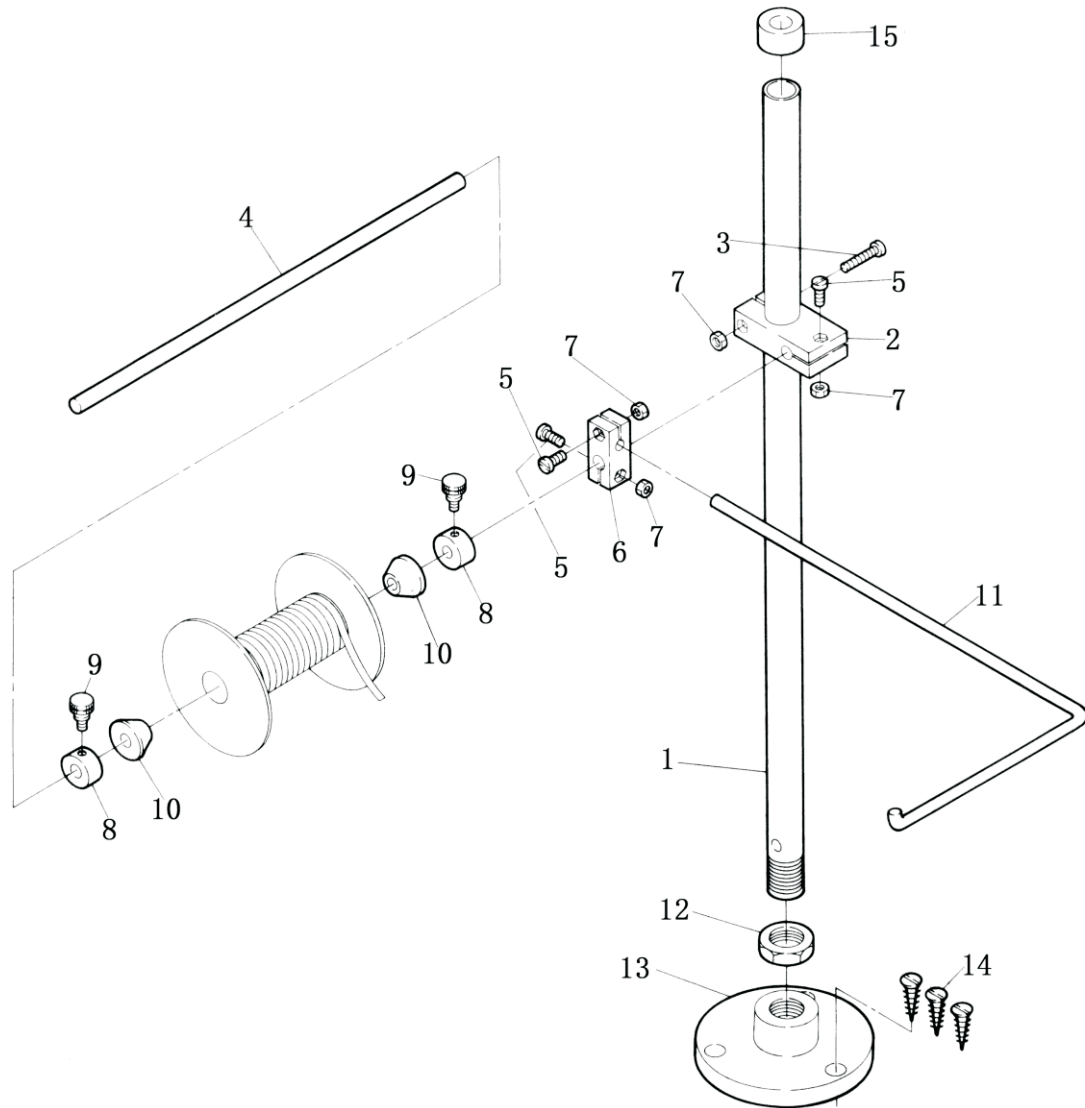

26. (500B-05)专用部件(4) SPECIFIC PARTS (4) (FOR 500B-05)

序号 NO.	注解 NOTE	图号 REF NO.	名称	DESCRIPTION	数量 AMT
1		311.28-01	杆	Hand Lifter Link	1
2		311.28-02	支架	Bar Rock Shaft	1
3		311.28-03	螺钉	Screw	1
4		311.28-04	棒	Stick	1
5		311.28-05	螺钉	Screw	3
6		311.28-06	固定器	Fixer	1
7		311.28-08	螺母	Nut	4
8		311.28-09	紧圈	Thrust Ring	2
9		311.28-10	螺钉	Screw	2
10		311.28-11	卷轴导向	Reel Lead Favor	2
11		311.28-12	辅助杆	Assistant Perch	1
12		311.28-15	螺母	Nut	1
13		311.28-16	线支架	Line Bar Rock Shaft	1
14		311.28-17	螺钉	Screw	3
15		311.28-18	塑料帽	Plastic Cap	1

27. (500B-05)专用部件(5) SPECIFIC PARTS (5) (FOR 500B-05)

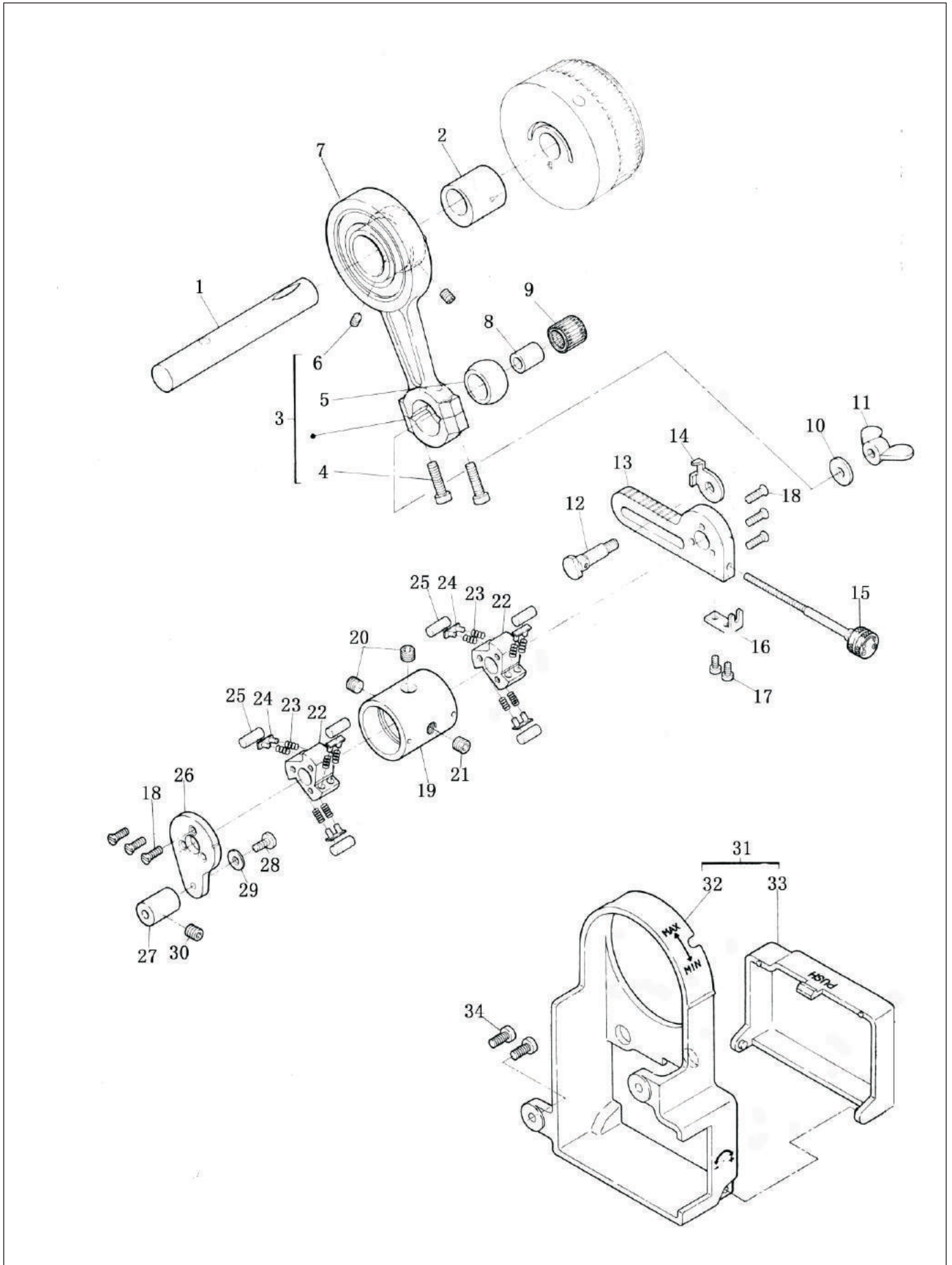

27. (500B-05)专用部件(5) SPECIFIC PARTS (5) (FOR 500B-05)

序号 NO.	注解 NOTE	图号 REF NO.	名称	DESCRIPTION	数量 AMT
1		311.29-01	上轴后节	Main Shaft Backside	1
2		311.29-02	偏心轮组件	Eccentricity Asm.	1
		311.29-02-1	偏心轮	Eccentricity	1
		311.29-02-2	偏心轮	Eccentricity	1
3		311.29-03	连接组件	Link Asm.	1
		311.29-03-01	轴承	Bearing	1
4		12-40401625-01	螺钉	Screw	(2)
5		311.29-03-2	球轴	Sphere Shaft	1
6		12-80500512-01	螺钉	Screw	2
7		311.29-03-4	连接上盖		(1)
		311.29-03-5	联接连杆		(1)
8		311.29-04	轴套	Bushing	1
9		311.29-05	滚针轴承	Needle Bearing	1
10		21-06215162-03	垫圈	Washer	1
11		311.29-07	螺母	Nut	1
12		311.29-08	销	Pin	1
13		311.29-09	曲柄	Brace	1
14		311.29-10	显示器	Display	1
15		311.29-11	螺钉	Screw	1
16		311.29-12	止动板	Stop Stir Board	1
17		12-40300625-01	螺钉	Screw	2
18		12-10401120-01	螺钉	Screw	6
		311.29-15-00	棘轮组件		1
19		311.29-15	轴套	Bushing	1
20		12-80600812-01	螺钉	Screw	2
21		12-80600812-01	螺钉	Screw	1
22		311.29-18	离合器	Clutch	2
23		311.29-19	弹簧	Spring	12
24		311.29-20	导向板组件	Guide Favor Board	6
25		311.29-21	销	Pin	6
26		311.29-22	止动板	Stop Stir Board	1
27		311.29-24	销	Pin	1
28		11-40110825-01	螺钉	Screw	1
29		21-04508080-01	垫圈	Washer	1
30		12-80500512-01	螺钉	Screw	1
31		311.29-28	盖(组件)	About Asm.	1
32		311.29-28-1	盖	About	1
33		311.29-28-2	盖	About	1
34		12-40401025-01	螺钉	Screw	2

28. (500B-05)专用部件(6) SPECIFIC PARTS (6)(FOR 500B-05)

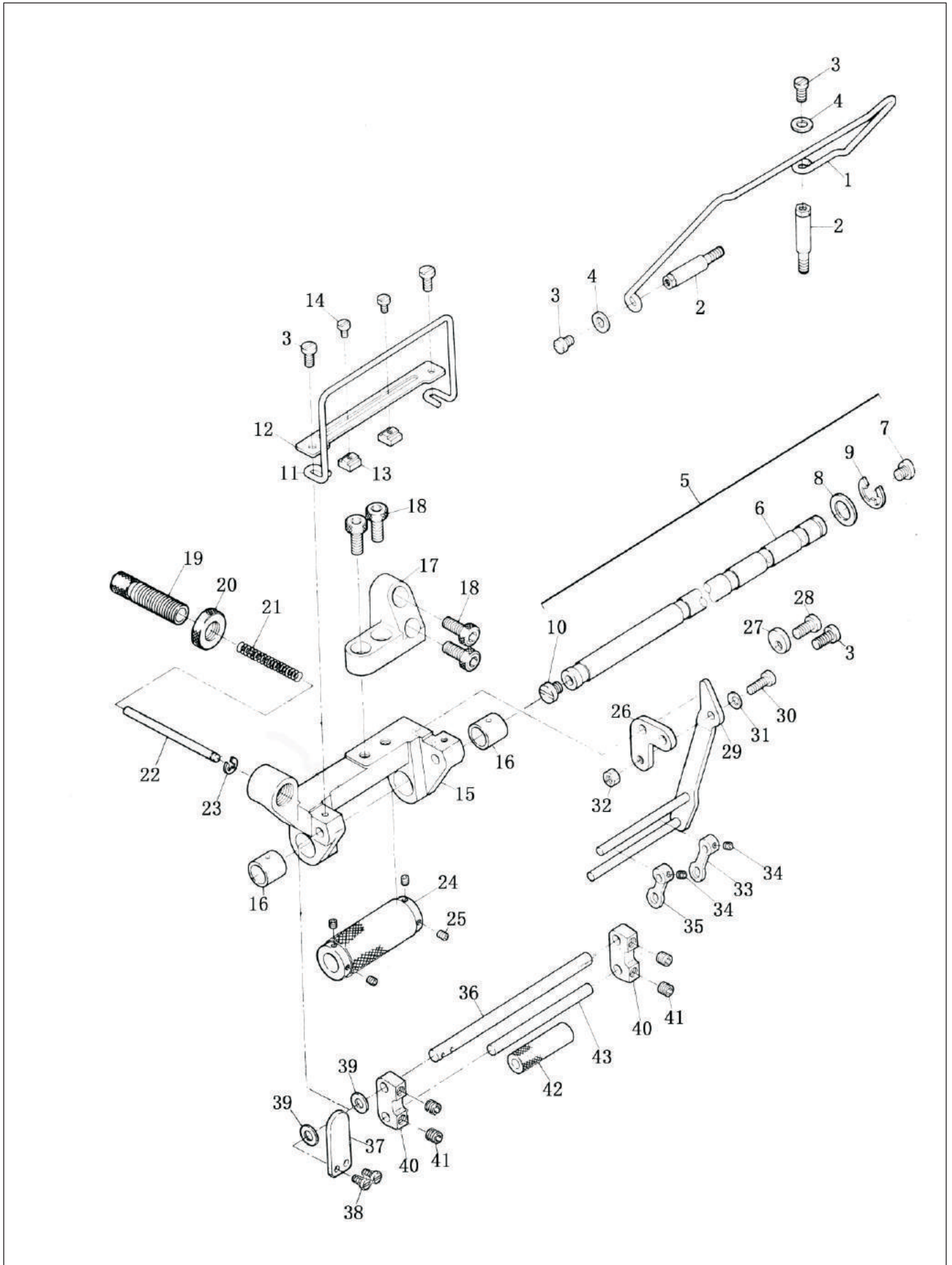

28. (500B-05)专用部件(6) SPECIFIC PARTS (6)(FOR 500B-05)

序号 NO.	注解 NOTE	图号 REF NO.	名称	DESCRIPTION	数量 AMT
1		311.30-01	花边导向器	Lace Lead Faver Ware	1
2		311.30-02	螺钉	Screw	2
3		12-40400825-01	螺钉	Screw	5
4		21-05310100-02	垫圈	Washer	2
5		311.30-05-01	轴组件	Shaft Asm.	1
6		311.30-05-1	轴	Shaft	1
7		12-60500520-01	螺钉	Screw	2
8		21-10212142-01	垫圈	Washer	1
9		24-08000000-08	卡簧	Retaining Ring	1
11		311.30-06	花边导向器	Screw	1
12		311.30-07	导向器	Lace Lead Faver Ware	1
13		311.30-09	滑块	Block	2
14		11-70060520-01	螺钉	Screw	2
15		311.30-11	支架	Bar Rock Shaft	1
16		311.30-12	轴套	Bushing	3
17		311.30-13	支架	Bar Rock Shaft	1
18		12-60601422-01	螺钉	Screw	4
19		311.30-16	螺钉	Screw	1
20		311.30-17	调节螺母	Nut	1
21		311.30-18	弹簧	Spring	1
22		311.30-19	轴	Shaft	1
23		24-03000000-08	卡簧	Retaining Ring	1
24		311.30-21	滚柱组件	Roll Mast Asm.	1
25		12-80300412-01	螺钉	Screw	4
26		311.30-23	支架	Bar Rock Shaft	1
27		311.30-24	止动片	Stop Stir Piece	1
28		12-40401025-01	螺钉	Screw	1
29		311.30-27	支架组件	Bar Rock Shaft Asm.	1
		311.30-27-01	托架柄		(1)
		311.30-27-02	托架杆		(2)
30		12-40401225-01	螺栓	Bolt	1
31		23-05003090-09	弹簧垫圈	Washer	1
32		14-60403020-01	螺母	Nut	1
33		311.30-31	花边导向器	Lace Lead Faver Ware	1
34		12-80300312-01	螺钉	Screw	2
35		311.30-33	花边导向器	Lace Lead Faver Ware	1
36		311.30-35	轴	Shaft	1
37		311.30-36	杠杆	Hand Lifter Link	1
38		12-40300625-01	螺钉	Screw	2
39		21-06510120-01	垫圈	Washer	2
40		311.30-39	支架	Bar Rock Shaft	2
41		12-80500512-01	螺钉	Screw	4
42		311.30-41	滚柱	Roll Mast	1
43		311.30-42	轴	Shaft	1
44		31-14818000-09	O形圈	O-ring	1
45		12-80500512-01	前套螺钉	Front Bushing Screw	2
46		311.05-1	带轮		1
47		311.06-1	针板		1
48		311.09-45	差动送布牙		1
49		311.09-46	主动送布牙		1
50		311.11-38	压脚		1

29. (500B-02HY)专用部件 SPECIFIC PARTS (FOR 500B-02HY)

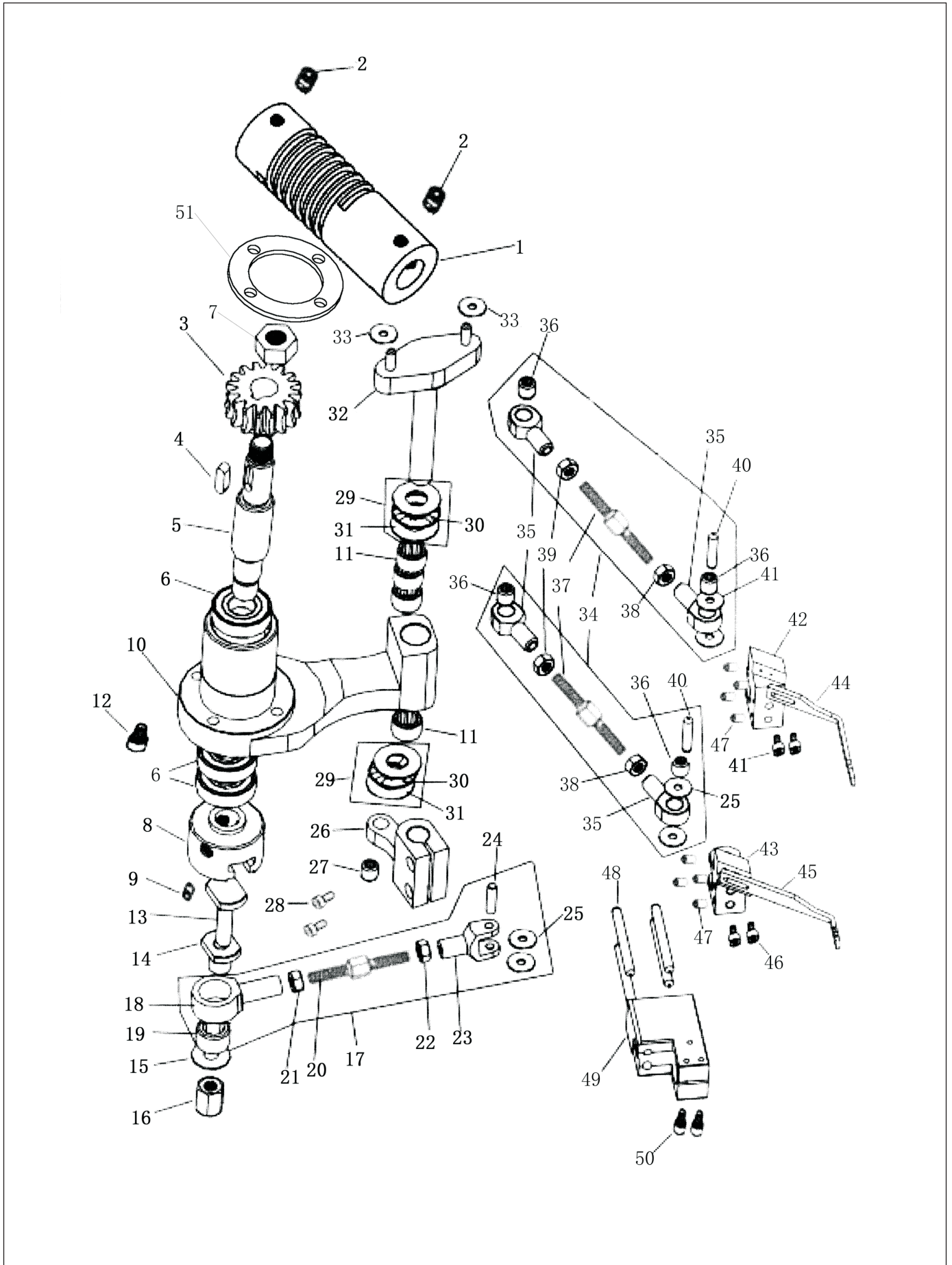

29. (500B-02HY)专用部件 SPECIFIC PARTS (FOR 500B-02HY)

序号 NO.	注解 NOTE	图号 REF NO.	名称	DESCRIPTION	数量 AMT
1		338.01-01	蜗杆	Worm	1
2		12-80600812-01	蜗杆紧定螺钉	Worm Fixing Nut	6
3		338.01-02	蜗轮	Worm Wheel	1
4		338.01-03	蜗轮花键	Worm Wheel Spline	1
5		338.01-04	蜗轮轴	Worm Wheel Shaft	1
6		338.01-05	蜗轮轴承 $\phi 15 \times \phi 32 \times 9$	Worm Wheel Shaft Bearing $\phi 15 \times \phi 32 \times 9$	3
7		338.01-06	蜗轮轴螺母	Worm Wheel Shaft Nut	1
8		338.01-07	偏心轮	Eccentricity Wheel	1
9		12-80801212-01	偏心轮紧定螺钉	Eccentricity Wheel Fixing Screw	3
10		338.01-08	支承架	Supporting Stand	1
11		338.01-08-01	滚针轴承 $\phi 12 \times \phi 16 \times 10$	Needle Bearing $\phi 12 \times \phi 16 \times 10$	4
12		12-60602022-01	支架固定螺钉	Stand Fixing Screw	4
13		338.01-09	摆动销A	Swing Pin A	1
14		338.01-10	摆动销B	Swing Pin B	1
15		338.01-11	摆动销垫片	Swing Pin Washer	1
16		338.01-12	摆动销螺母	Swing Washer Nut	1
17		338.01-13	摆动连杆组件	Swing Connecting Rod Asm	1
18		338.01-13-01	连杆A	Connecting Rod	1
19		338.01-08-01	连杆A轴承	Connecting Rod Bearing	1
20		338.01-13-03	拉杆	Lever	1
21		14-60605020-02	拉杆螺母	Lever Nut	1
22		338.01-13-05	拉杆螺母	Lever Nut (left)	1
23		338.01-13-06	连杆B	Connecting Rod B	1
24		338.01-13-07	连杆B连接销	Connecting Rod B Connecting Pin	1
25		338.01-13-08	垫片	Washer	2
26		338.01-14	摆动曲柄	Swing Crank	1
27		338.01-14-01	滚针轴承 $\phi 5 \times \phi 9 \times 9$	Needle Bearing	1
28		12-60501622-01	摆动曲柄螺钉	Swing Crank Screw	2
29		338.01-16	平面推力滚针组件	Horizontal Pushing Needle Bearing Asm	2
30		279.03-07	平面推力滚针	Horizontal Pushing Needle Bearing	2
31		279.03-07	推力滚针垫片 $\phi 12 \times \phi 26 \times 10$	Pushing Needle Bearing Washer	4
32		338.01-17	摆动轴组件	Swing Shaft Asm	1
33		338.01-13-08	垫片	Washer	2
34		338.01-19	拉杆组件	Lever Asm	2
35		338.01-19-01	拉杆接头	Lever Connector	4
36		338.01-19-02	拉杆接头滚针 $\phi 5 \times \phi 9 \times 9$	Lever Connector Needle Bearing $\phi 5 \times \phi 9 \times 9$	4
37		338.01-19-03	拉杆	Lever	2
38		338.01-13-05	拉杆螺母	Lever Nut	2
39		14-60605020-02	拉杆螺母	Lever Nut (right)	2
40		338.01-19-06	拉杆销	Lever Pin	2
41		338.01-13-08	垫片	Washer	4
42		338.01-20	拨线座A	Drawing Thread Set A	1
43		338.01-21	拨线座B	Drawing Thread Set B	1
44		338.01-22	拨线杆A	Drawing Thread Bar A	1
45		338.01-23	拨线杆B	Drawing Thread Bar B	1
46		12-60301022-01	拨线杆固定螺钉	Drawing Thread Bar Fixing Screw	4
47		12-80400412-01	拨线座螺钉	Drawing Thread Set Screw	8
48		338.01-26	拨线座定位销	Drawing Thread Posion Pin	4
49		338.01-27	拨线座定位块	Drawing Thread Set Posion Plate	1
50		12-60402522-01	拨线座定位块固定螺钉	Drawing Thread Set Posion Plate Fixing Screw	2
51		338.01-47	垫片	Washer	1

29. (500B-02HY)专用部件 SPECIFIC PARTS (FOR 500B-02HY)

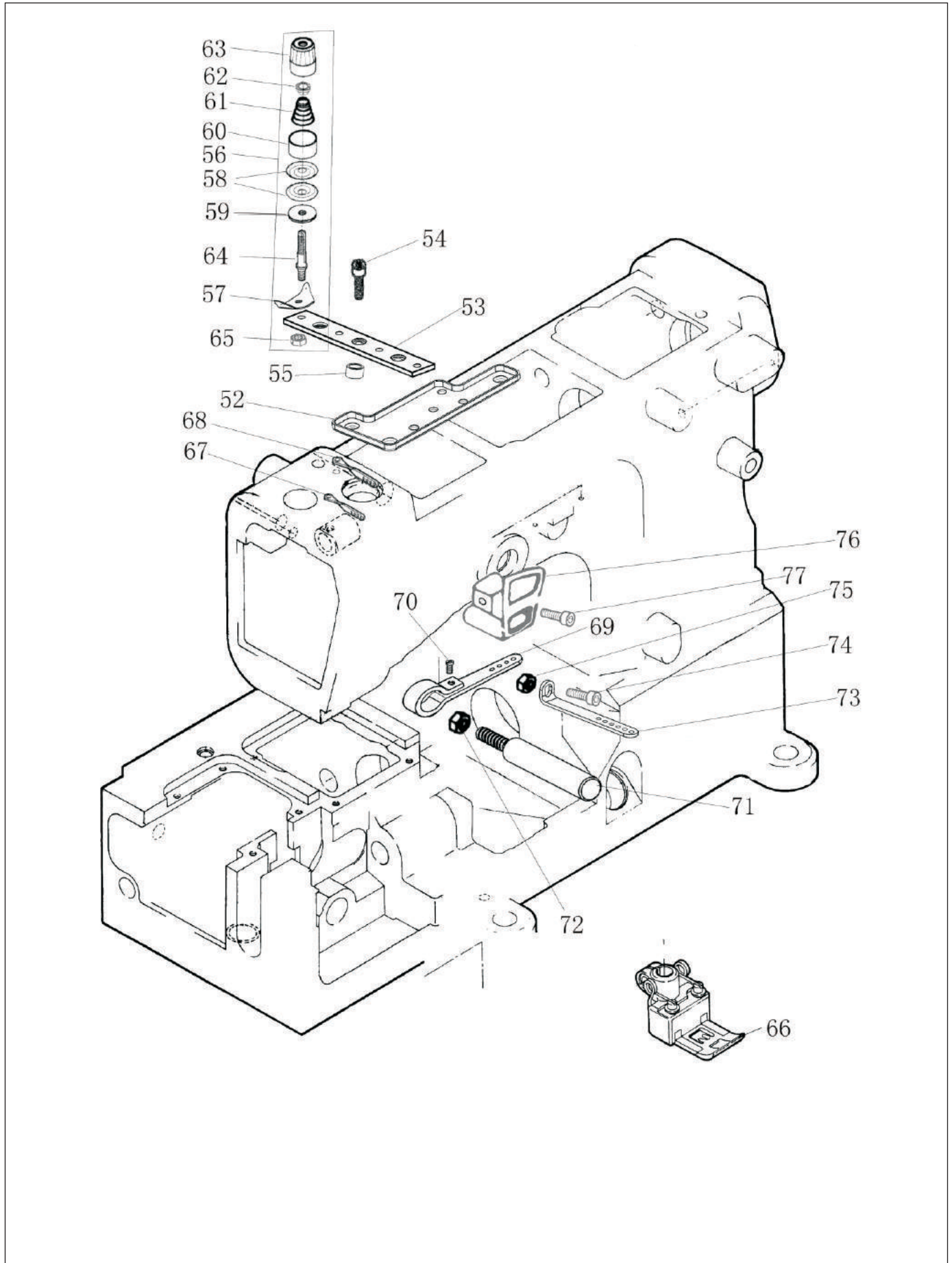

29. (500B-02HY)专用部件 SPECIFIC PARTS (FOR 500B-02HY)

序号 NO.	注解 NOTE	图号 REF NO.	名称	DESCRIPTION	数量 AMT
52		304.16-01	小油盘	Small Oil Pan	1
53		338.01-30	压线座固定架	Press Fixing Bracket	1
54		12-60501622-01	压线座固定架螺钉	Press Fixing Bracket Screw	1
55		338.01-32	压线座固定架垫片	Press Fixing Bracket Washer	3
56		338.01-33	压线器组件	Presser Asm	4
57		203.01-22	过线板	Thread Guide Plate	4
58		301.13-10	夹线板	Thread Tension Plate	8
59		338.01-33-03	羊毛毡	Wool Felt	4
60		301.13-15	夹线座	Thread Tension Set	4
61		301.13-18	夹线弹簧	Thread Tension Spring	4
62		301.13-11	夹线防松圈	Thread Tension Protect Loosing Ring	4
63		301.13-12	夹线螺母	Thread Tension Screw	4
64		301.13-25	夹线螺钉	Nut	4
65		14-60403020-01	螺母M4	Presser Foot Complete	4
66		338.01-34	压脚组件	Presser Foot Complete	1
		338.01-34-01	压脚座	Presser Foot Bracket	(1)
		338.01-34-02	压杆座	Presser Bar Bracket	(1)
		338.01-34-03	压脚	Presser Foot Complete	(1)
		338.01-34-04	压脚压板	Presser Foot Plate	(1)
		338.01-34-05	压脚接头	Presser Foot Connector	(1)
		302.11-08	压脚销	Presser Foot Pin	(1)
		338.01-34-07	压脚接头销	Presser Foot Connection Pin	(1)
		338.01-34-08	压杆座弹簧	Presser Bar Bracket Spring	(1)
		338.01-34-09	压脚压簧	Presser Foot Press Sping	(1)
		338.01-34-10	压杆座调节螺钉	Presser Bar Set Regulating Screw	(1)
		338.01-34-11	压簧螺钉	Presser Spring Screw	(2)
		338.01-34-12	压脚压板螺钉	Presser Foot Pressing Plate Screw	(1)
		338.01-34-13	压杆座销紧定螺钉	Presser Bar Fixing Screw	(1)
		338.01-34-14	调节螺钉螺母	Regulating Screw Nut	(1)
67		338.01-35	上过线勾A	Upper Thread Guide Finger A	2
68		338.01-36	上过线勾B	Upper Thread Guide Finger B	1
69		338.01-37	下过线勾A	Lower Thread Guide Finger A	1
70		12-60400822-01	下过线勾A螺钉	Lower Thread Guide Finger A Screw	1
71		338.01-39	下过线勾A支柱	Lower Thread Guide Finger A Stand	1
72		14-60403020-01	下过线勾A支柱螺母	Lower Thread Guide Finger A Stand Screw	1
73		338.01-41	下过线勾B	Lower Thread Guide Finger B	1
74		12-60400822-01	下过线勾B螺钉	Lower Thread Guide Finger B Screw	1
75		14-60403020-01	下过线勾B螺母	Lower Thread Guide Finger B Screw	1
76		338.01-44	挑线杆防护罩	Thread Take-up Lever Shaft Shield	1
77		12-40401225-01	螺钉	Screw	2
78		338.01-46	油杯	Oil Cup	1

30. (500B-04)专用部件 SPECIFIC PARTS (FOR 500B-04)

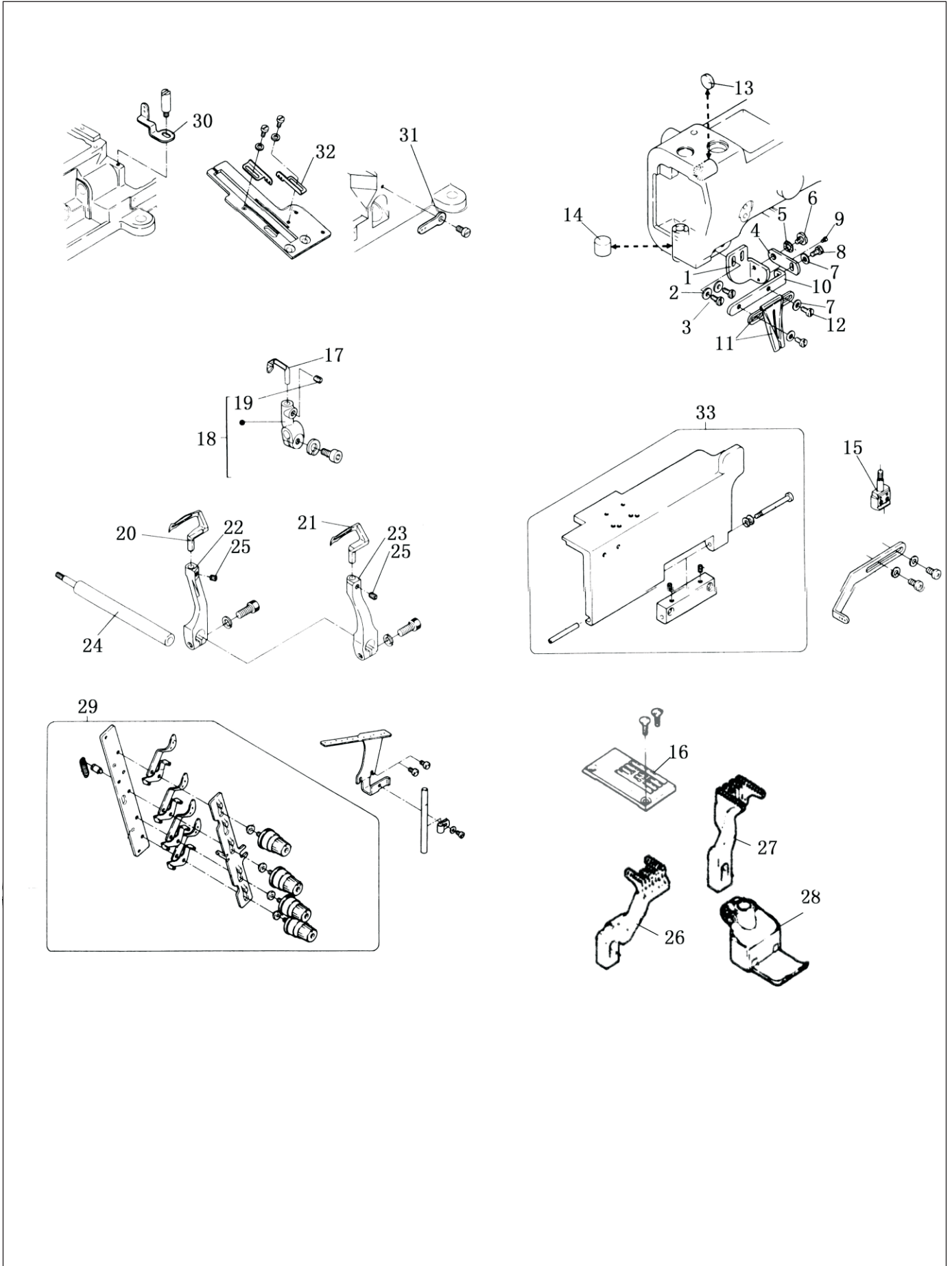

30. (500B-04)专用部件 SPECIFIC PARTS (FOR 500B-04)

序号 NO.	注解 NOTE	图号 REF NO.	名称	DESCRIPTION	数量 AMT
1		310.33-01	卷边龙头支座	Folder Bracket	1
2		21-04308090-02	垫片	Washer	2
3		12-40400825-01	螺钉	Screw	2
4		310.33-04	侧板	Side Plate	1
5		23-06405110-09	鞍型垫圈	Wave Washer	1
6		301.02-25	螺钉	Screw	1
7		21-04308090-02	垫片	Washer	3
8		12-90400723-01	外六角螺钉	Svrew	1
9		310.33-09	定位螺钉	Orientation Screw	1
10		310.33-10	卷边龙头固定板	Folder Fixing Plate	1
11		310.33-11	卷边龙头	Folder	1
12		12-40400625-01	螺钉	Screw	2
13		304.01-25	绷杆横轴油塞	Oil Seal For Spreader Crossing Shaft	1
14		310.33-14	绷杆竖轴油堵	Oil Seal For Spreader Uprinat Shaft	1
15		310.33-15	针夹	Needle Holder	1
		310.33-15(7.2)	针夹	Needle Holder	1
16		310.33-16	针板	Needle Plate	1
		310.33-16(7.2)	针板	Needle Plate	1
17		310.33-17	后保针	Rear Needle Guard	1
18		310.33-18	保针座	Needle Guard Base	1
19		12-80400412-01	螺钉	Screw	1
20		310.33-20	左弯针	Left Looper	1
21		310.33-21	右弯针	Right Looper	1
22		310.33-22	左弯针曲柄	Left Looper Crank	1
23		310.33-23	右弯针曲柄	Right Looper Crank	1
24		310.33-24	弯针轴	Looper Shaft	1
25		12-80400412-01	弯针刀槽螺钉	Looper Groove Screw	2
26		310.33-26	差动送布牙	Differential Feed Dog	1
		310.33-26(7.2)	差动送布牙	Differential Feed Dog	1
27		310.33-27	主动送布牙	Main Feed Dog	1
		310.33-27(7.2)	主动送布牙	Main Feed Dog	1
28		310.33-28	压脚(组件)	Presser Foot Arm.	1
		310.33-28-01	压脚座		(1)
		310.33-28-02	压脚		(1)
		310.33-28-03	销	Pin	(2)
		310.33-28(7.2)	压脚(组件)	Presser Foot Arm.	1
		310.33-28-01	压脚座		(1)
		310.33-28-02(7.2)	压脚底板		(1)
		310.33-28-03	销	Pin	(2)
29		310.33-29	夹线器大组件	Thread Tension Spring Arm.	1
30		310.33-30	过线板	Thread Guide Plate	1
31		310.33-31	过线板	Thread Guide Plate	1
32		310.33-32	下过线板	Lower Thread Guide Plate	2
33		301.21-04	穿线罩板	Thread Guide Plate	1
34		279.12-04	线架组件		1

31. (500B-21)专用部件SPECIFIC PARTS FOR (500B-21)

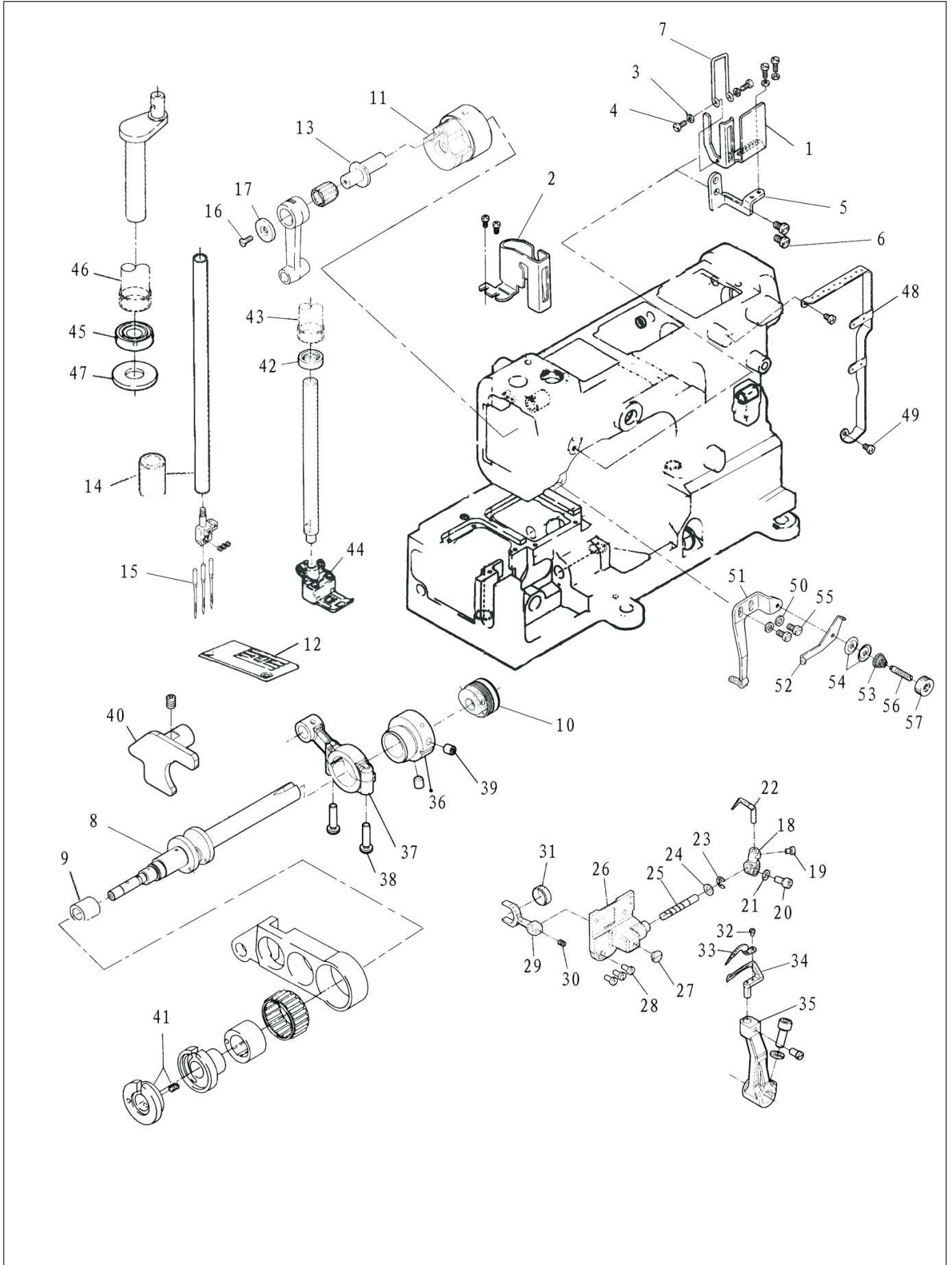

31. (500B-21)专用部件SPECIFIC PARTS FOR (500B-21)

序号 NO.	注解 NOTE	图号 REF NO.	名称	DESCRIPTION	数量 AMT
1		340.02-07	挑线防护罩	Threading Cover Spring	1
2		340.02-09	上挑线罩座	Thread Take—up Lever Guard	1
3		21-04308090-02	垫片	Washer	4
4		12-40400625-01	螺钉	Screw	4
5		340.02-34	护板支架	Shield Bracket	1
6		12-40601025-01	螺钉	Screw	2
7		340.02-36	挑线防护罩钢丝	Pick The Line Protection Cover Steel Wire	1
8		340.04-10	下轴前轴节	Lower Shaft Forepart	1
9		343.04-30	下轴前套	Lower Shaft Front Bushing	1
10		343.04-09	下轴前衬套组件	Lower Shaft Front Bushing Asm.	1
<hr/>					
		301.19-09	轴承	Berings	1
		343.04-09-02	下轴前衬套	Lower Shaft Front Bushing	1
		31-32014000-09	O型圈	O-ring	2
11		340.05-14	针杆曲柄	Needle Bar Crank	1
12		340.06-02	针板	Needle Plate	1
13		340.06-15	针杆连接销	Needle Bar Connecting Pin	1
14		340.06-18	针杆下套	Needle Bar Lower Bushing	1
15		340.06-24	机针	Needl Uy128gas #12s	3
16		12-10300620-01	螺钉	Screw	1
17		340.06-27	垫片	Washer	1
<hr/>					
18		311.25-04	护针座	Needle Guard Base	1
19		12-40400525-01	螺钉	Screw	1
20		12-60501022-01	护针座螺钉	Needle Guard Base Screw	1
21		22-05000000-08	弹性垫圈	Washer	1
22		301.07-03	后护针	Rear Needle Guard	1
23		24-05000000-08	开口挡圈	Snap Thrust Ring	1
24		21-06210101-01	垫圈	Washer	1
25		311.25-10	护针轴	Needle Guard Shaft	1
26		343.07-09	护针轴座组件	Bracket Asm.	1
		311.25-11	支架	Bracket	1
<hr/>					
		311.25-23	套筒	Copper Bushing	1
27		12-60600420-01	螺钉	Screw	1
28		12-40400825-01	螺钉	Screw	3
29		343.07-12	护针曲柄	Needle Guard Crank	1
30		12-80500512-01	螺钉	Screw	1
31		343.07-14	护针曲柄滑套	Needle Guard Crank Slippery Set	1
32		12-40250425-01	前护针螺钉	Screw	1
33		301.07-21	前保针	Front Needle Guard	1
34		340.08-02	弯针	Looper	1
35		343.08-03	弯针曲柄	Looper Crank	1
<hr/>					
36		343.08-26	偏心凸轮	Eccentricity Cam	1
37		343.08-27	弯针连杆组件	Looper Link Lever Asm.	1
		343.08-27-01	弯针连杆	Looper Link Lever	(1)
38		12-40401625-01	连杆螺钉	Link Lever Screw	(2)
39		12-80500612-01	凸轮螺钉	Cam Screw	3
40		343.09-38	牙架右限位板	Feed Rack Right Stopper Plate	1
41		301.09-15-02	针距调节套组件	Needle Distance Regulator Bushing Asm.	1
		301.09-15	针距调节套	Needle Distance Regulator Bushing	(1)
		340.09-15-02	定位螺钉	Screw	(1)
42		32-08440150-09	油封	Oilfelt	1
43		343.11-12	压紧杆套	Presser Bar Bushing	1

31. (500B-21)专用部件 SPECIFIC PARTS FOR (500B-21)

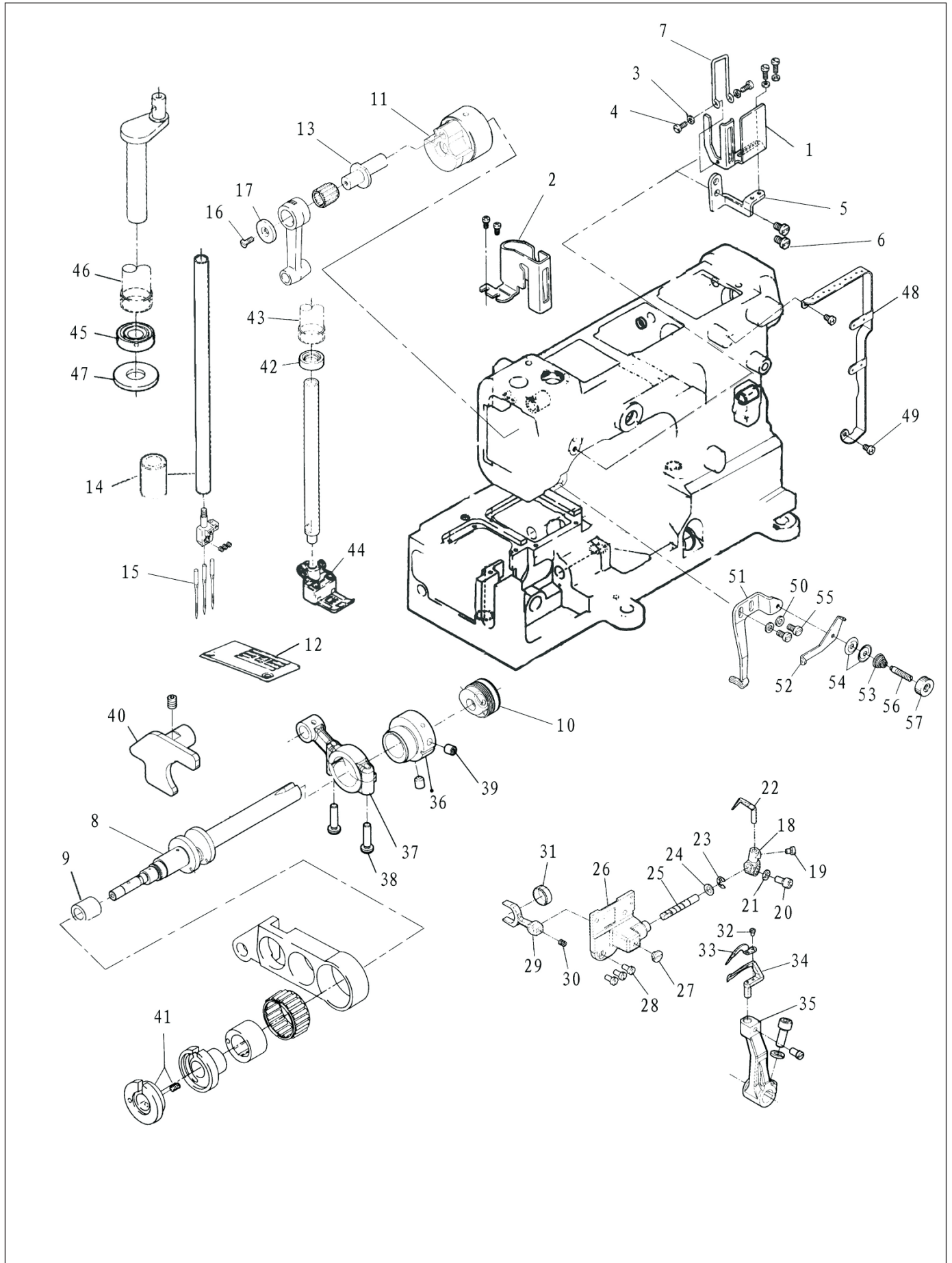

31. (500B-21)专用部件 SPECIFIC PARTS FOR (500B-21)

序号 NO.	注解 NOTE	图号 REF NO.	名称	DESCRIPTION	数量 AMT
44		340.11-38	压脚组件	Presser Foot Asm	1
		340.11-38-01	压脚扭簧 (右)		(1)
		340.11-38-02	压脚		(1)
		340.11-38-03	压脚压簧		(1)
		340.11-38-04	压脚护板		(2)
		340.11-38-05	螺钉		(1)
		340.11-38-06	压脚滑板		(2)
		340.11-38-07	压脚柄		(1)
		340.11-38-08	压脚扭簧 (右)		(1)
		340.11-38-09	圆柱销		(2)
		340.11-38-10	圆柱销		(1)
		340.11-38-11	螺钉		(1)
		340.11-38-12	螺钉		(1)
		340.11-38-13	螺钉		(1)
45		32-09440190-09	油封	Oilfelt	1
46		340.12-14	绷针轴竖套	Stretch Tight Needle Upright Bushing	1
47		21-10220232-03	垫圈	Washer	1
48		340.13-07	过线架	Thread Eyelet Stand	1
49		12-40400525-01	螺钉	Screw	2
50		21-04308090-02	垫圈	Washer	2
51		340.14-05	绷针线下过线板	Lower Thread Guide Plate	1
52		301.14-06	绷针过线板	Thread Guide Plate	1
53		209.19-13	压线簧	Presser Spring	1
54		209.19-12	过线压板	Presser Plate	2
55		12-40400825-01	螺钉	Screw	2
56		209.19-11	夹线螺钉	Screw	1
57		209.19-14	夹线螺母	Nut	1

32. (500A-01)专用部件 SPECIFIC PARTS(FOR 500A-01)

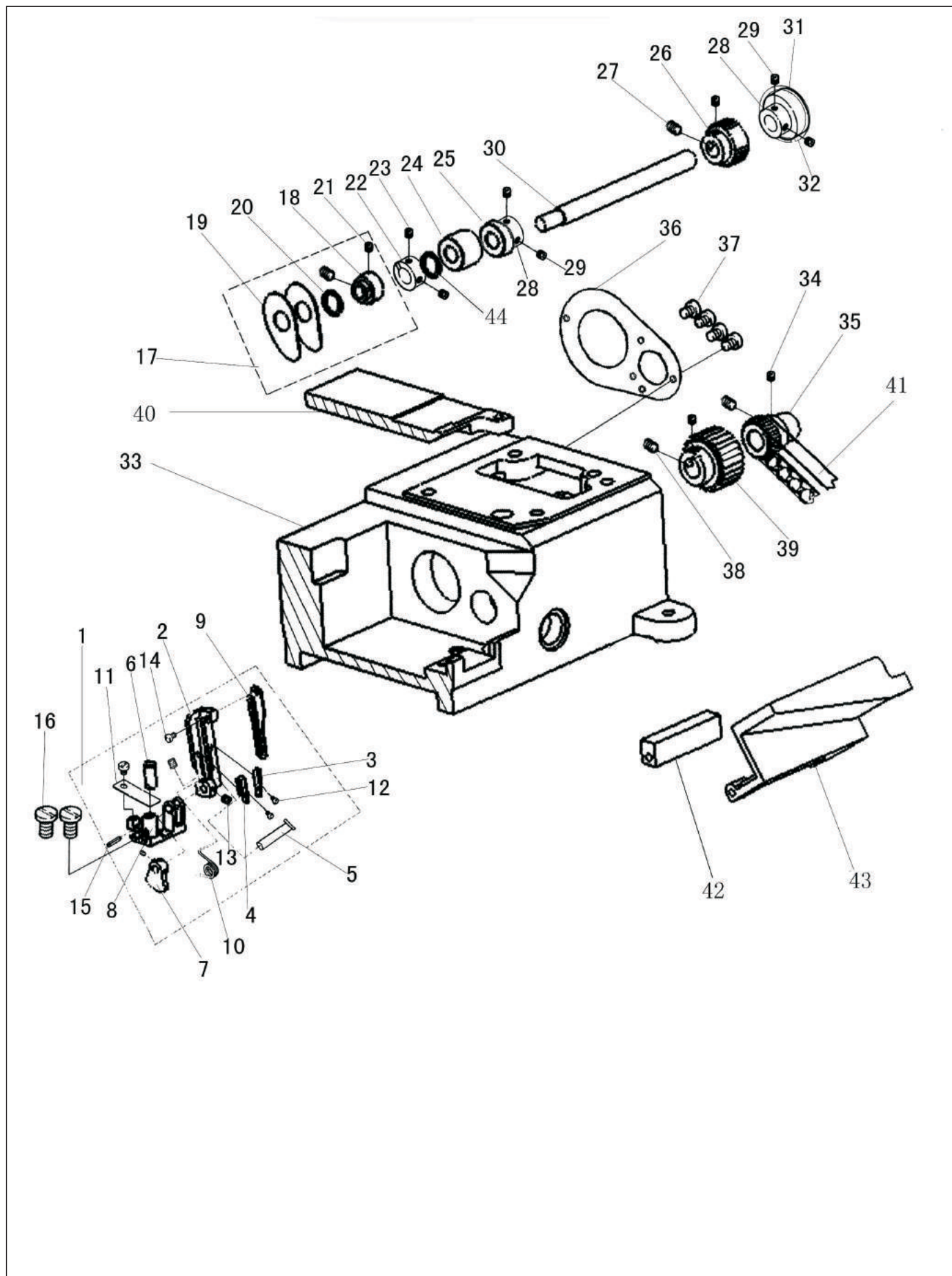

32. (500A-01)专用部件 SPECIFIC PARTS(FOR 500A-01)

序号 NO.	注解 NOTE	图号 REF NO.	名称	DESCRIPTION	数量 AMT
1		21-04308090-02	垫圈	Washer	1
2		301.18-02	硅油储盒盖	Silicone Oil Reservoir Cover	1
3		301.18-03	硅油储盒	Silicone Oil Reservoir	1
4		301.18-04	硅油盒油毡	Silicone Oil Reservoir Felt	1
5		301.18-05	硅油盒壳体	Silicone Oil Reservoir Body	1
6		42-07005000-00	硅油输油管	Silicone Oil Efferent	0.135
7		279.09-20	大头针	Pin	1
8		301.18-08	上硅油毡	Silicone Oil Felt (upper)	1
9		301.18-09	上硅油盖	Silicone Oil Cover (upper)	1
10		301.18-10	上硅油盒	Silicone Oil Case (upper)	1
11		41-20200500-00	开口弹簧销 $\phi 2 \times 5$	Elastic Pin $\Phi 2 \times 16$	2
12		301.18-12	油线压板	Oil Wick Press Plate	1
13		43-10250000-00	油线	Oil Wick	0.27
14		301.16-19-01	弹簧管夹头(小)	Spring Tube Collet	2
15		12-40401025-01	螺钉	Screw	1
16		12-40400625-01	螺钉	Screw	1
17		12-40300625-01	螺钉	Screw	2
18		11-40090525-01	螺钉	Screw	2

获行业首家 全国质量奖

GEMSY GAINED CHINA QUALITY AWARD -- THE FIRST ONE TO WIN THIS AWARD IN SEWING MACHINE FIELD

全国服务热线：800-8576-822

SERVICE HOTLINE: 800-8576-822

GEMSY 宝石  **中国驰名商标**  **中国名牌产品**  **中国出口名牌**  **全国用户满意产品**         

地址：中国浙江省台州市东环大道638号 P.C: 318000

国内营销部：DOMESTIC SALES DEPARTMENT

TEL: 0576-88201401 88202041

FAX: 0576-88202667 88203211

Http://www.gemsy.com

ADD: NO.638 DONGHUAN ROAD, TAIZHOU, ZHEJIANG, CHINA

国际贸易部：INTERNATIONAL TRADE DEPARTMENT

TEL: 0086-576-88201479 88201471 88207338

FAX: 0086-576-88202667 88203211

E-mail : gemsy@gemsy.com